

Kawasaki Robot Palletizing robots

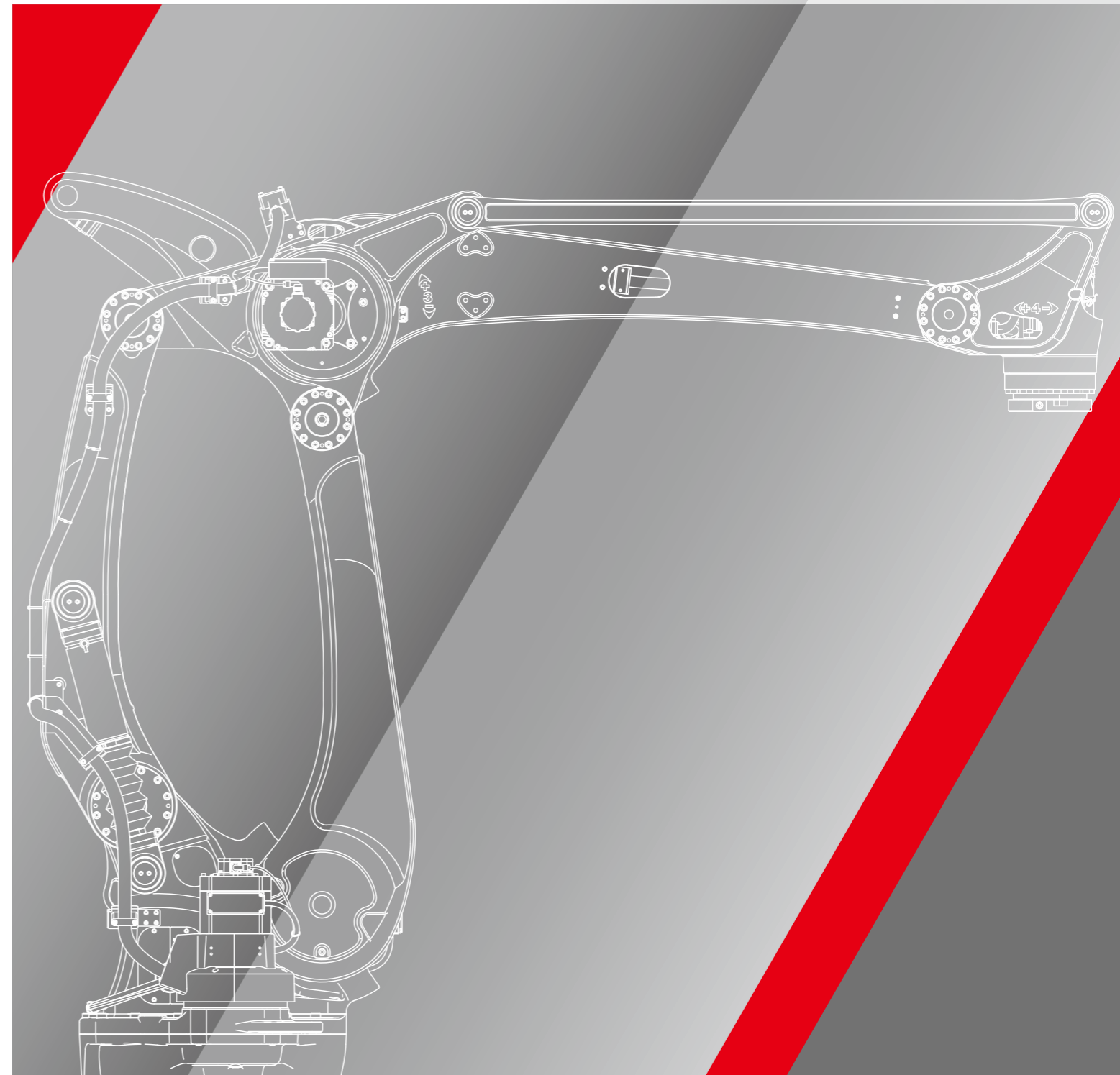

Kawasaki Heavy Industries, Ltd.

ROBOT DIVISION

Tokyo Head Office/Robot Division

1-14-5, Kaigan, Minato-ku, Tokyo 105-8315, Japan
Phone: +81-3-3435-2501 Fax: +81-3-3437-9880

Akashi Works/Robot Division

1-1, Kawasaki-cho, Akashi, Hyogo 673-8666, Japan
Phone: +81-78-921-2946 Fax: +81-78-923-6548

Global Network

Kawasaki Robotics (USA), Inc.

28140 Lakeview Drive, Wixom, MI 48393, U.S.A.
Phone: +1-248-446-4100 Fax: +1-248-446-4200

Kawasaki Robotics (UK) Ltd.

Unit 4 Easter Court, Europa Boulevard, Westbrook Warrington
Cheshire, WA5 7ZB, United Kingdom
Phone: +44-1925-71-3000 Fax: +44-1925-71-3001

Kawasaki Robotics GmbH

29 Sperberweg, 41468 Neuss, Germany
Phone: +49-2131-34260 Fax: +49-2131-3426-22

Kawasaki Robotics Korea, Ltd.

43, Namdong-daero 215beon-gil, Namdong-gu, Incheon, 21633,
Korea
Phone: +82-32-821-6941 Fax: +82-32-821-6947

Kawasaki Robotics (Tianjin) Co., Ltd.

1-2/F, Building 6, No.19 Xinhuan Road, TEDA, China
Phone: +86-22-5983-1888 Fax: +86-22-5983-1889

Kawasaki Motors Enterprise (Thailand) Co., Ltd.

(Rayong Robot Center)
119/10 Moo 4 T.Pluak Daeng, A.Pluak Daeng, Rayong 21140
Thailand
Phone: +66-38-955-040-58 Fax: +66-38-955-145

<https://robotics.kawasaki.com/>

Kawasaki Robot

CAUTIONS TO BE TAKEN TO ENSURE SAFETY

- For those persons involved with the operation / service of your system, including Kawasaki Robot, they must strictly observe all safety regulations at all times. They should carefully read the Manuals and other related safety documents.
- Products described in this catalogue are general industrial robots. Therefore, if a customer wishes to use the Robot for special purposes, which might endanger operators or if the Robot has any problems, please contact us. We will be pleased to help you.
- Be careful as Photographs illustrated in this catalogue are frequently taken after removing safety fences and other safety devices stipulated in the safety regulations from the Robot operation system.



ISO certified in Akashi Works.

Kawasaki's high-speed palletizing robots meet the demands for flexibility and speed.

In today's highly competitive marketplace, meeting the demand for just-in-time deliveries, flexible packaging, the freshest products, or the highest production line efficiencies can be crucial to a company's success. Efforts to meet these demands have led to the development of automation systems for the end-of-line and distribution processes of palletizing and depalletizing. Kawasaki's robotic palletizing solutions provide the pallet pattern flexibility, tooling flexibility, and cycle times needed to deal with multi-variety and small-batch production, and reduce process change costs.

Kawasaki Robotics offers three different lines of palletizing robots with a wide range of payload options to suit most needs, including model RD80N with a maximum payload of 80 kg, models ZD130S/250S with maximum payloads of 130/250 kg and models CP180L/300L/500L/700L with maximum payloads of 180/300/500/700 kg. Each has industry leading reach, speed and quality to deliver high-performance automation technology for most any palletizing application.

Kawasaki can provide a solution to give your production line the palletizing flexibility and product rate it needs to compete in today's economy.



RD80N



ZD130S/250S



CP180L/300L



CP500L



CP700L



Features

Palletizing capacity worthy of our high-speed age

Kawasaki palletizing robots deliver the high-speed operation needed for distribution. Based on a robot stroke of 400 mm upward-downward and 2,000 mm in the left-right direction, the RD080N can perform 900 cycles per hour with loads of 80 kg, and the CP180L achieves an industry leading 2,050 cycles per hour with loads of 130 kg.

Compact applications

The Kawasaki RD080N is designed specifically for applications where a compact, high-speed, palletizing robot is required. Despite its slim space saving design, the RD80N can manipulate loads up to 80 kg and create pallet stacks over 2 meters tall.

Large work envelope and high payload capacity

At 3,075 mm and 3,256 mm respectively, the high vertical reach capability of the ZD and CP series robots is ideal for tall pallet stacks and multi-lane applications. The extra-long horizontal reach of 3,255 mm for both series allows for one robot to be used to cover up to four pallets. The high payload capacity CP series robots can handle up to 700 kg. This allows for multiple product picks and complete pallet layer handling, resulting in fewer cycles per completed pallet.

Easy-to-use palletizing software K-SPARC

Available as an option, Kawasaki's K-SPARC palletizing software enables users to quickly and easily simulate layout planning and operations, as well as create robot operation programs on a computer.

Space and energy saving

The CP series E03 controller is only 25% of the standard palletizing* controller size (41% with transformer unit) and fits under conveyors and other equipment. The E03 controller generates electric power while in a deceleration mode, reducing energy consumption and minimizing CO₂ emissions.

* in case of E4X

Electricity Regeneration Function

Conventional controller

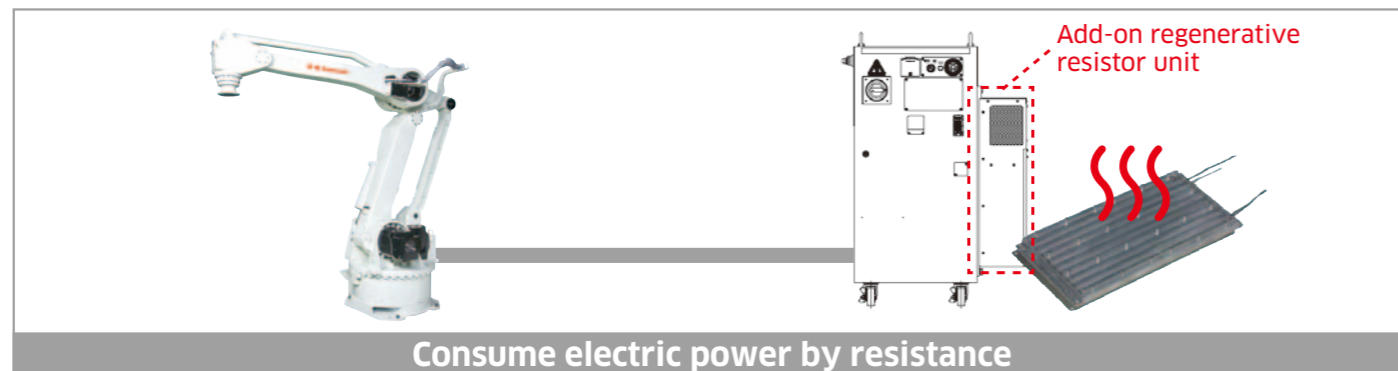

E03 Controller

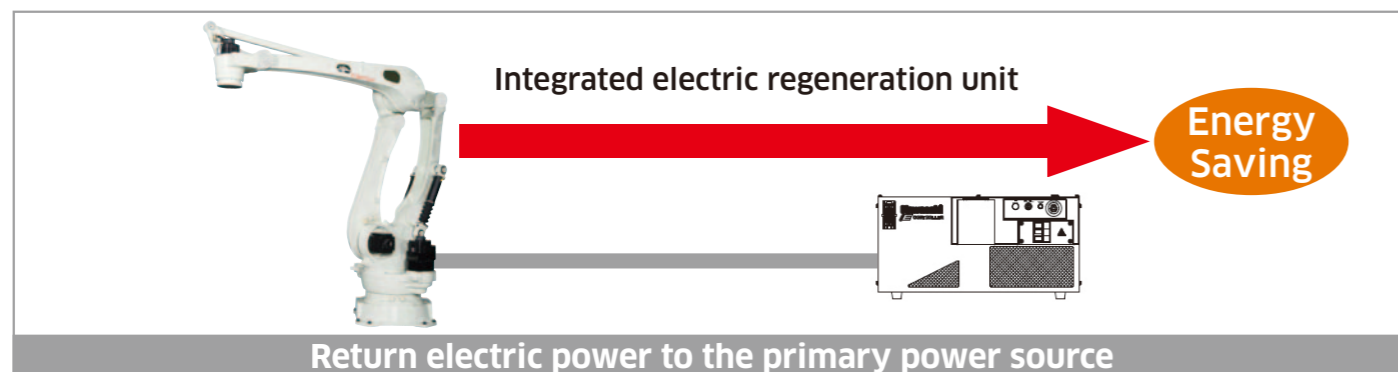

Palletizing cells

Kawasaki provides system configurations perfectly adapted to your needs.

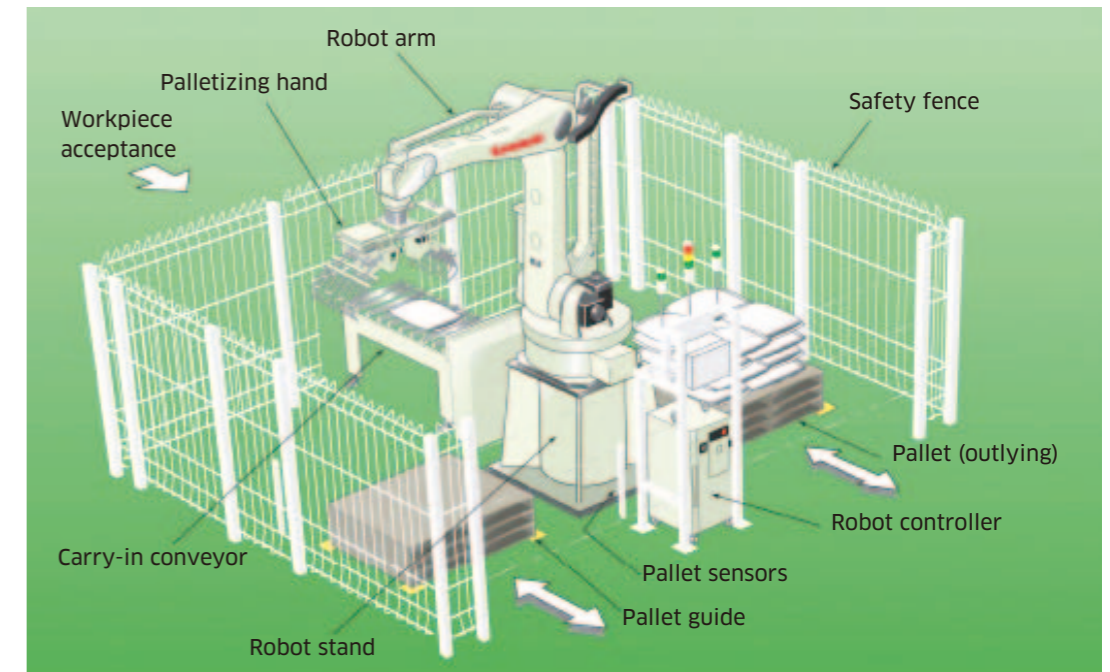

Sample layout for palletizing cells

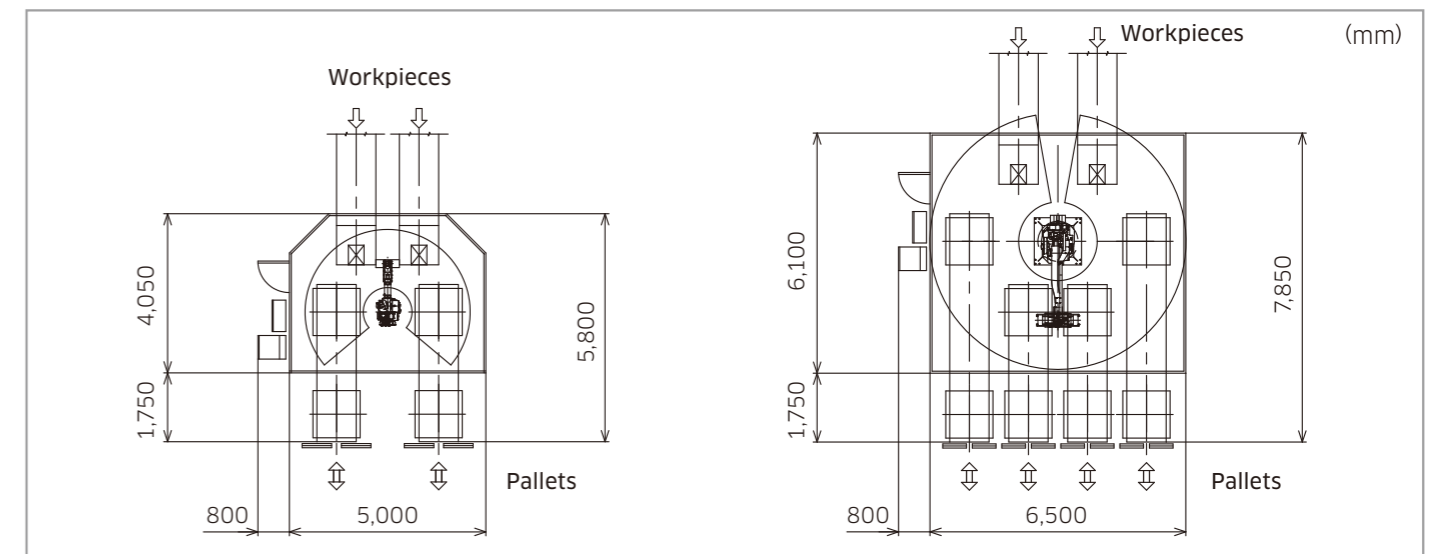

Sample of palletizing cells

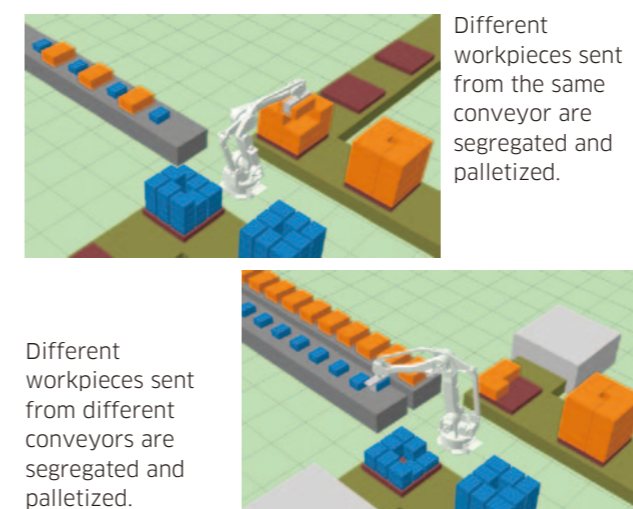

Different workpieces sent from the same conveyor are segregated and palletized.

Different workpieces sent from different conveyors are segregated and palletized.

System configuration example

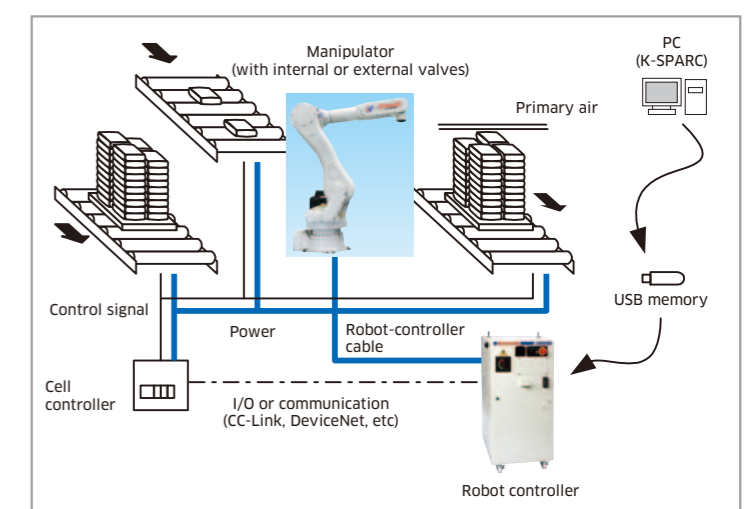

Depalletizing cells

- Detects the 3-D position and posture of stacked bag packages.
- A single fixed camera can monitor wide stacking areas.
- Able to adjust to changes in peripheral lighting environments and workpiece surface conditions.
- No need for configuring the individual settings of each workpiece stacking pattern.
- Able to handle a combination of different types of workpieces at the same time.

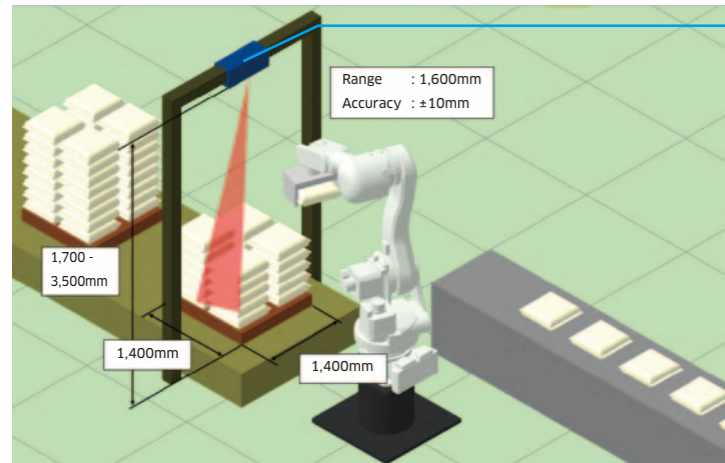

LSC (Laser Slit-scan Camera)



Item	Specification
Measuring range	L1,400mm×W1,400mm×L1,800mm
Objective distance	1,700mm
Laser class	Class 3R
Dimension	L1,100mm×W125mm×H125mm
Mass	About 6.5kg

System configuration example

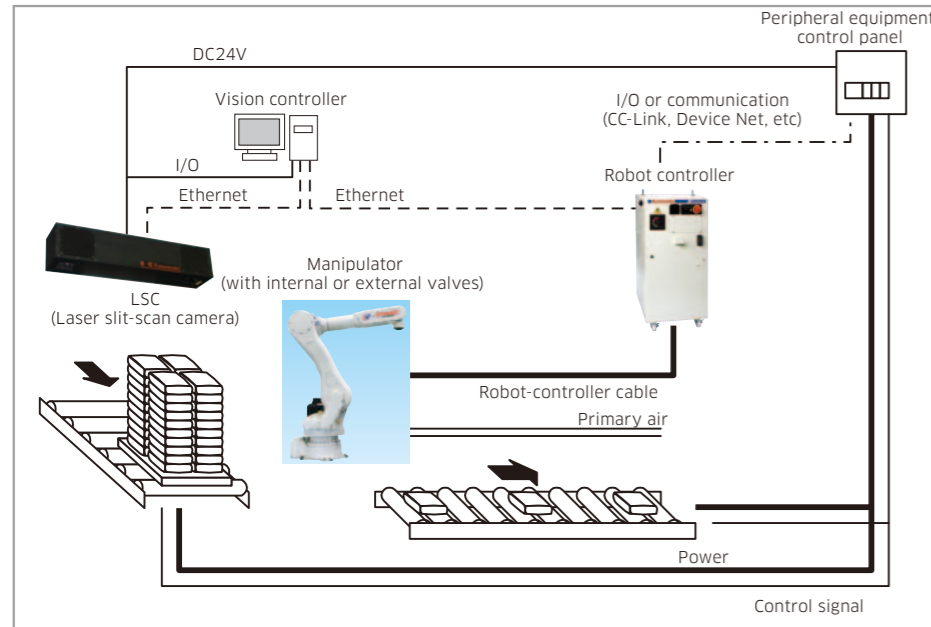

Other applications

*For these applications, the workpiece sizes and stacking patterns must be configured.

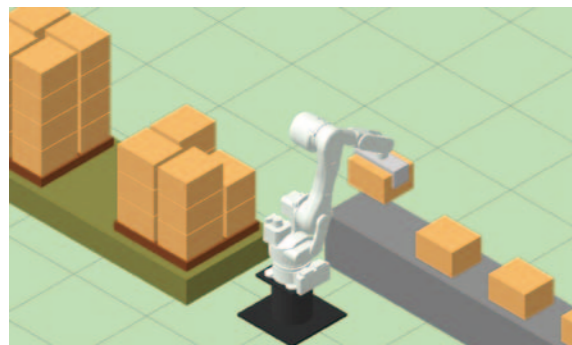

Depalletizing carton boxes

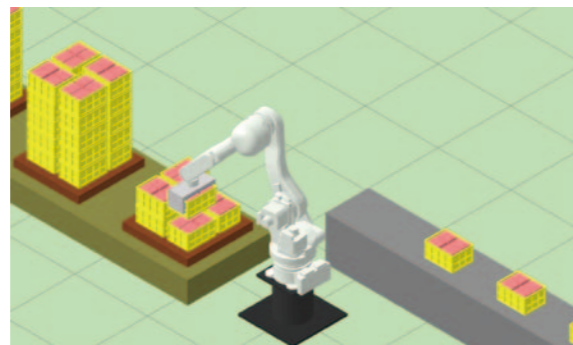

Depalletizing plastic containers

Easy-to-use palletizing software



Supervise Safety Smart



You can build an advanced and flexible robot safety system according to the motion condition by monitoring the movements of the robot.

- Save Space by limiting the range of robot movements
- Safety function can be switched according to the state of safety signal input
- IEC61508 (SIL2) and ISO13849-1 (PLd/category 3) certification

Save space

You can reduce the size of the safety fence area by limiting the range of robot movements to the minimum.

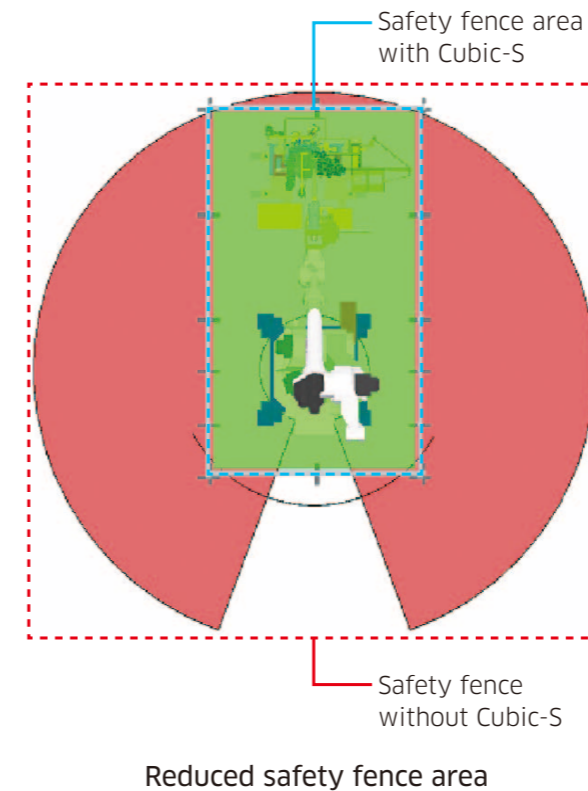

Transporting workpieces during robot motion

You can limit the range of robot movements according to the human work area.

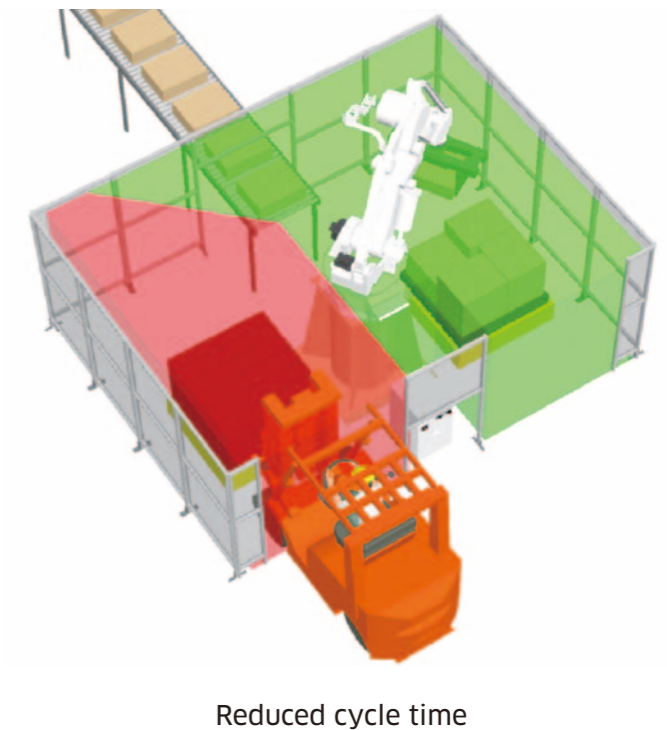

Item	Specification
Safety performance	IEC61508 (SIL2) ISO13849-1 (PLd/category3)
Monitoring the number of joints	Maximum 9 joints
Safety function	Motion area monitoring, Joint monitoring, Speed monitoring, Stand still monitoring, Tool orientation monitoring, Protective stop, Emergency stop, Safety status output
Safety input and output	Dual channel safety input 8CH Dual channel safety output 8CH * It is possible to allocate Safety Status Output Signals and Safety Input Signals of each Safety functions

RD080N

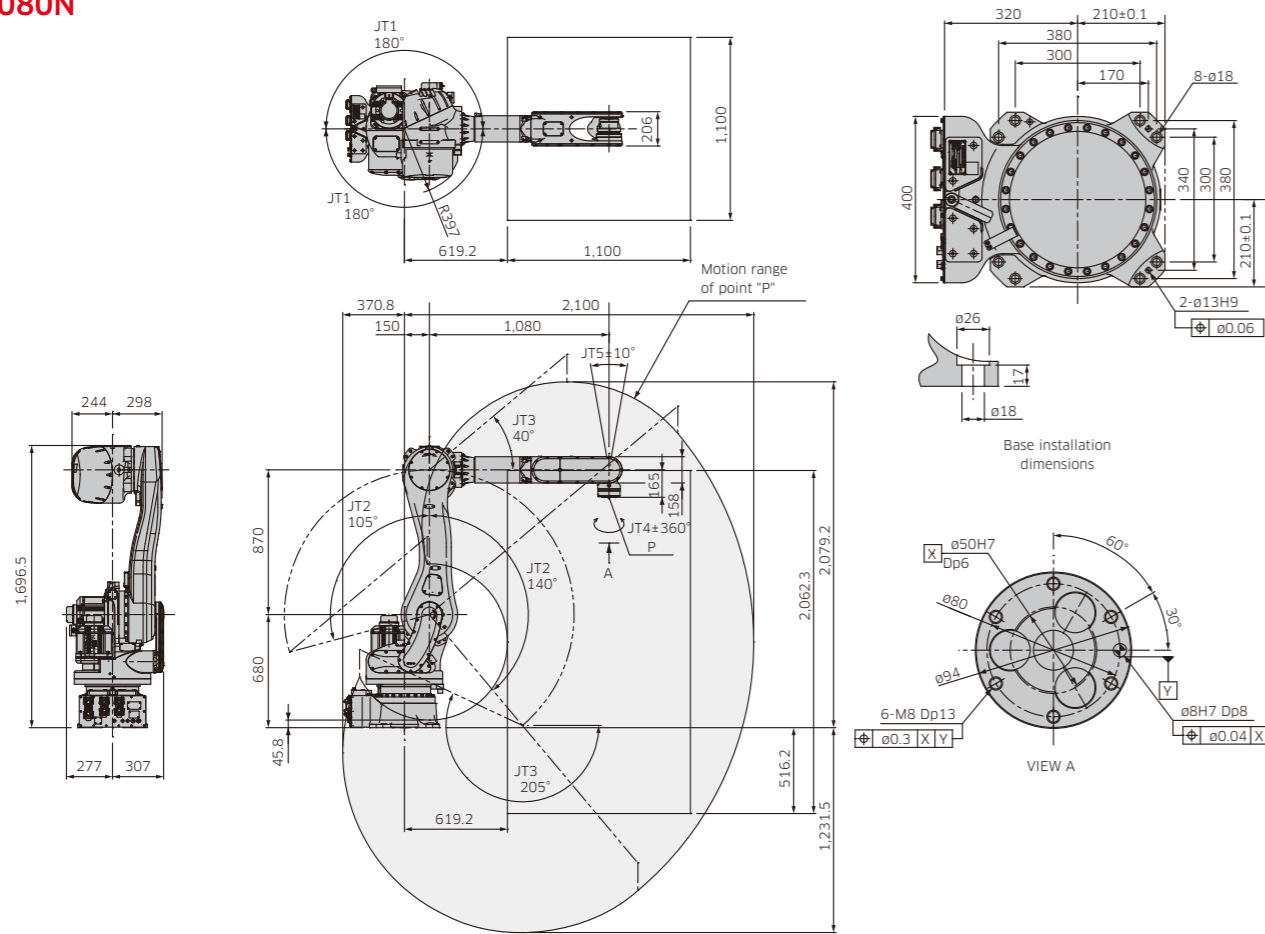

(mm)

CP180L/300L

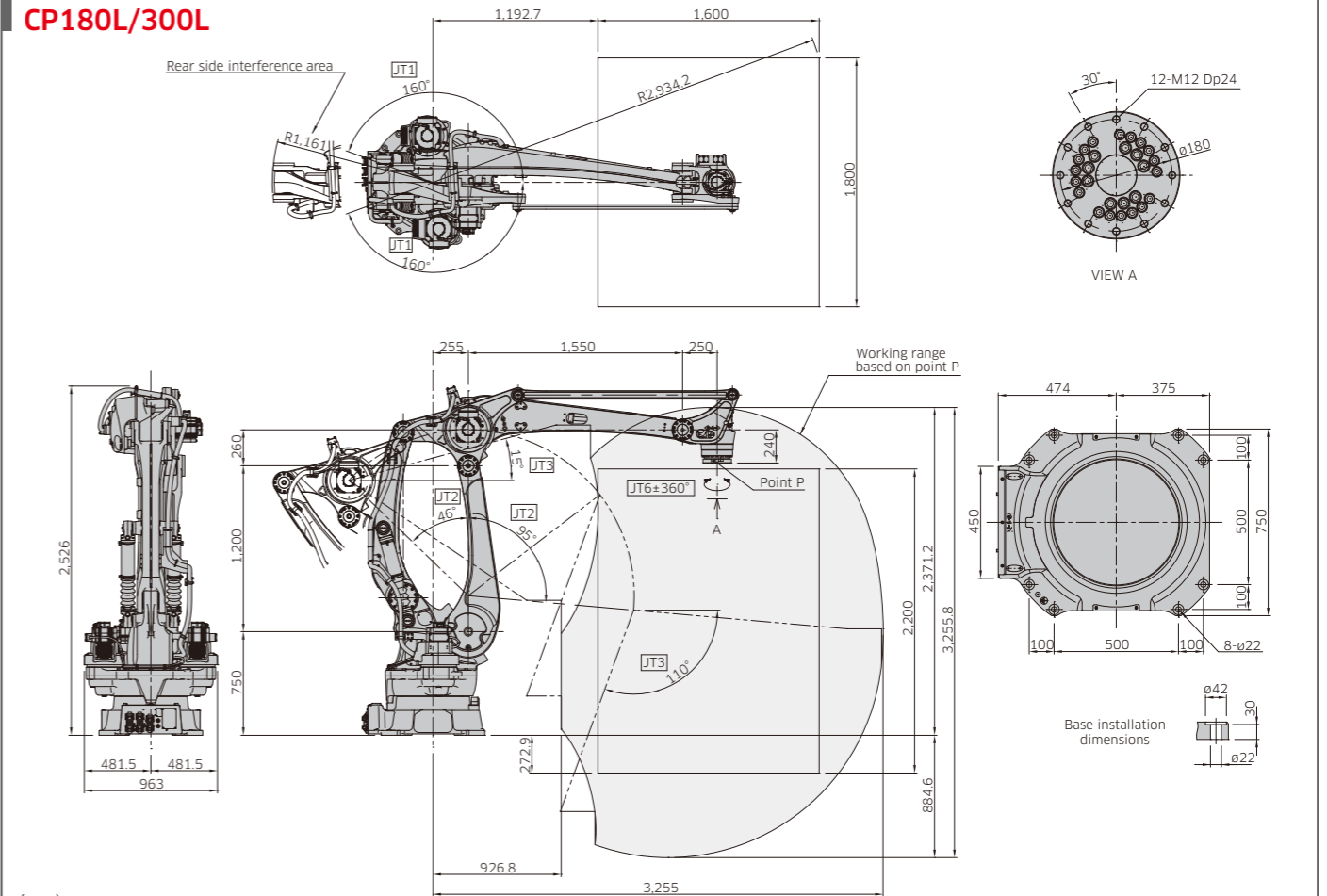

(mm)

ZD130S/250S

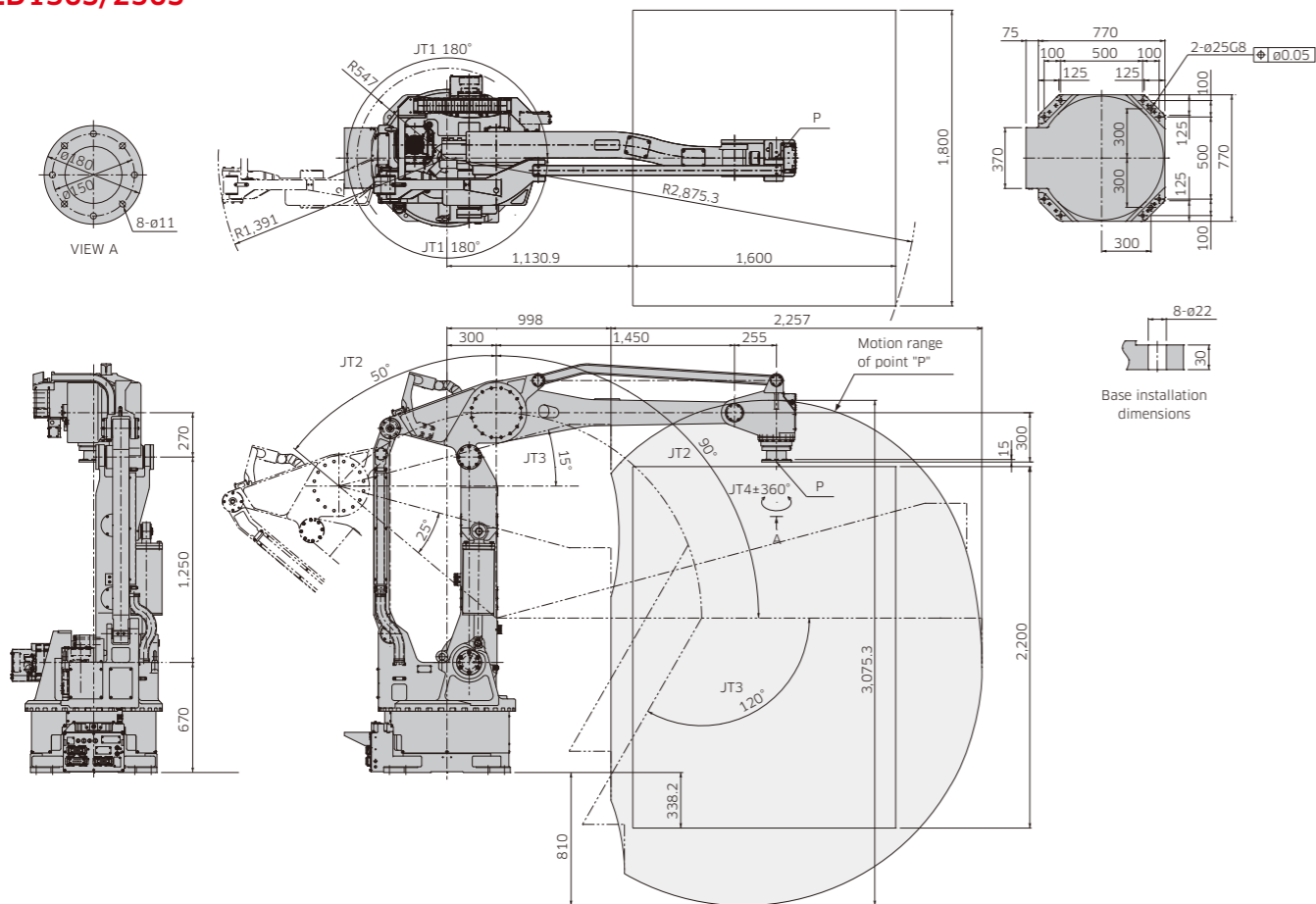

(mm)

CP500L

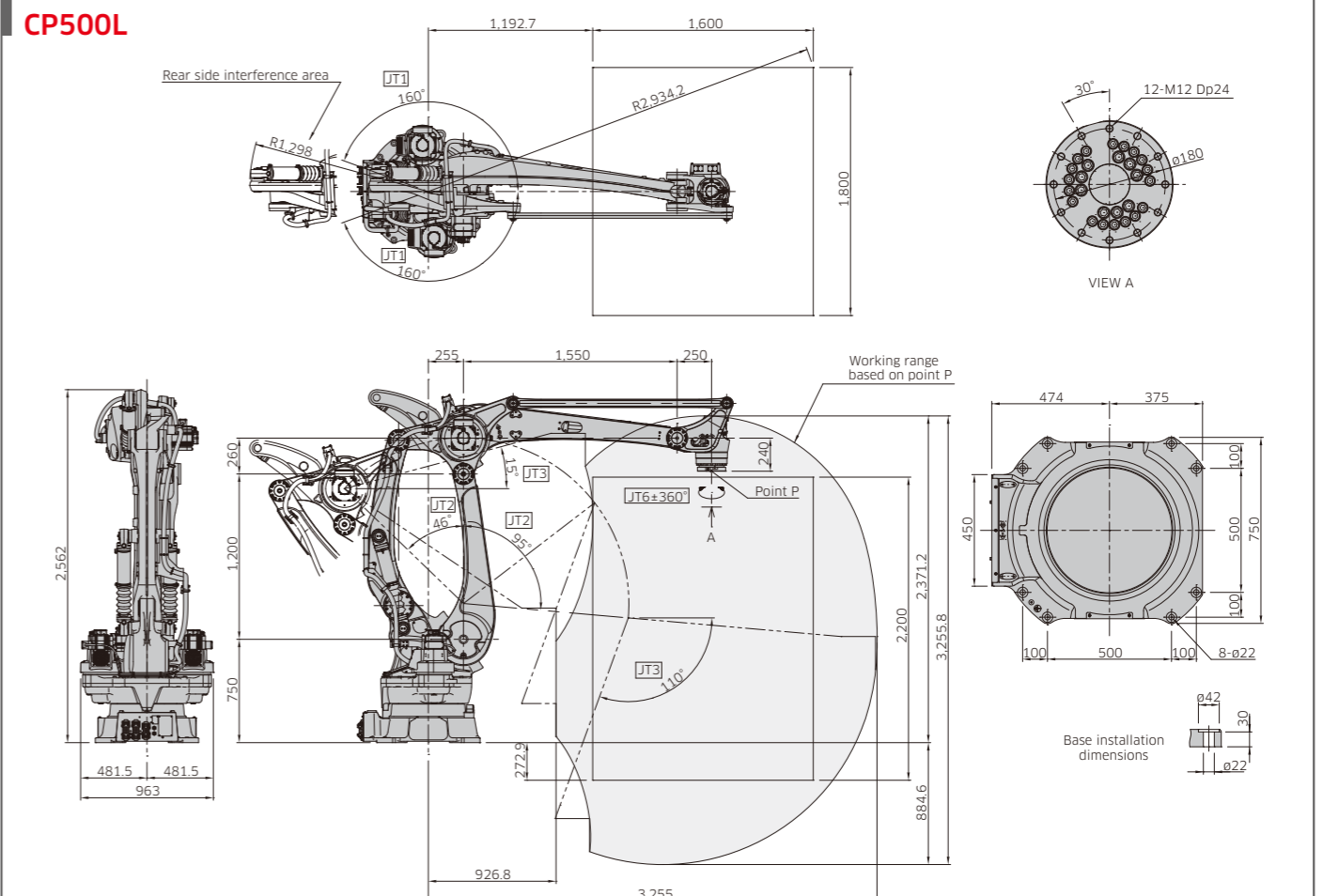

(mm)

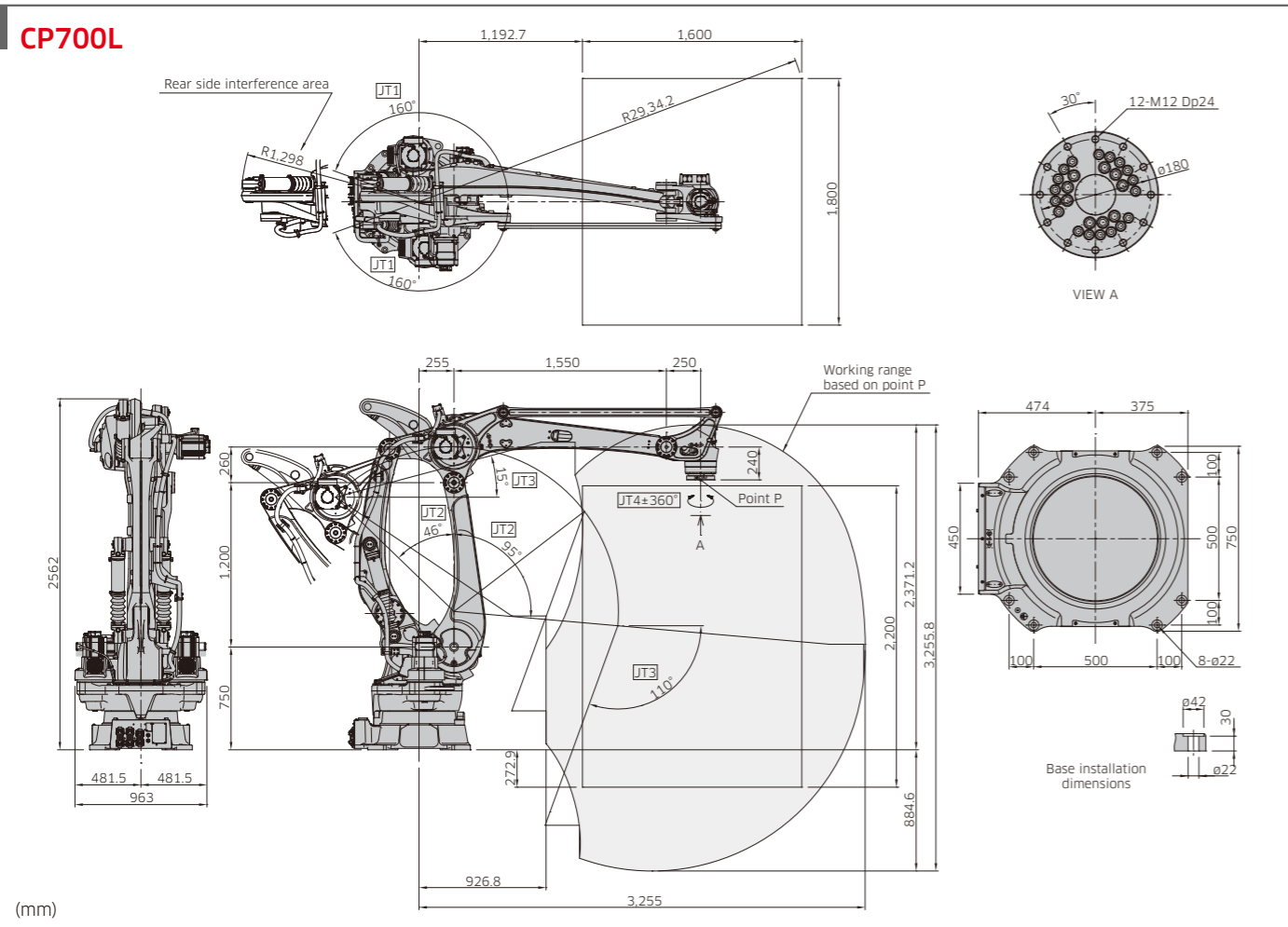

		RD080N	ZD130S	ZD250S
Arm type		Articulated type		
Degrees of freedom (axes)		5		
Max. payload (kg)		80	130	250
Max. stroke (°)	Arm rotation (JT1)	±180		
	Arm out-in (JT2)	+140 - -105		
	Arm up-down (JT3)	+40 - -205		
	Wrist swivel (JT4)	±360		
	Wrist compensation (JT5)	±10 *4		
Max. speed (°/s)	Arm rotation (JT1)	180	148	95
	Arm out-in (JT2)	180	110	90
	Arm up-down (JT3)	175	130	95
	Wrist swivel (JT4)	360	400	190
Working area (mm)	Width	1,100		
	Depth	1,100		
	Height	2,062.3		
Moment of inertia (kg·m ²)		13.7	50	100
Palletizing capacity *1 (cycle/hour)		900	1,700	1,400
Positional repeatability *2 (mm)		±0.07		
Mass (kg)		540		
Power requirements *3 (kVA)		4.5		
Controller	America	E33		
	Europe	E43		
	Japan & Asia	E23		

*1: Motion pattern (400 mm up, 2,000 mm horizontal, 400 mm down in a to-and-fro motion) *2: conforms to ISO9283
 *3: depends on the payload condition and motion patterns *4: operating angle of the JT5 is ±10 degrees perpendicular to the ground.

		CP180L	CP300L	CP500L	CP700L
Arm type		Articulated type			
Degrees of freedom (axes)		4			
Max. payload (kg)		180	300	500	700
Max. stroke (°)	Arm rotation (JT1)	±160			
	Arm out-in (JT2)	+95 - -46			
	Arm up-down (JT3)	+15 - -110			
	Wrist swivel (JT4)	±360			
	Wrist compensation (JT5)	-			
Max. speed (°/s)	Arm rotation (JT1)	140 *5	115 *6	85	75
	Arm out-in (JT2)	125 *5	100 *6	80	65
	Arm up-down (JT3)	130 *5	100 *6	80	65
	Wrist swivel (JT4)	400 *5	250 *6	180	170
Working area (mm)	Width	1,800			
	Depth	1,600			
	Height	2,200			
Moment of inertia (kg·m ²)		50 *5	100 *6	250	500
Palletizing capacity *1 (cycle/hour)		2,050 *5	1,700r *6	1,000	900
Positional repeatability *2 (mm)		±0.5			
Mass (kg)		1,600		1,650	
Power requirements *3 (kVA)		12			
Controller	America	E03			
	Europe	E03			
	Japan & Asia	E03			

*1: Motion pattern (400 mm up, 2,000 mm horizontal, 400 mm down in a to-and-fro motion) *2: conforms to ISO9283
 *3: depends on the payload condition and motion patterns *5: in case of 130 kg payload and less *6: in case of 250 kg payload and less

E series

The E Controller combines high performance, unprecedented reliability, a host of integrated features and simple operation, all in a compact design.

Features

Compact

The E03 controller for CP series palletizing robots has far less volume. You can use it in an upright-position or in a stacked installation to reduce the footprint of this controller.

User-friendly operation

The easy-to-use teach pendant now incorporates motor power and cycle start at your fingertips. Multiple information screens can be displayed simultaneously. The intuitive teaching interface is simple to use.

Programming ease & flexibility

A rich set of programming functions come standard with the E Controller to support a wide range of applications. Functions can be combined and easily configured within a system to suit a particular application. Also, the powerful Kawasaki AS Programming Language provides sophisticated robot motion and sequence controls.

Advanced technologies

The enhanced CPU capacity allows for more accurate trajectory control, faster program execution, and quicker loading and saving of files. In addition, memory has been expanded to meet the need for higher program storage capacity. The controller comes equipped with a USB port for external storage devices.

Easy maintenance

Modular components with limited cables translate into easy diagnostics and maintenance. A host of maintenance functions are available, including self-diagnostics on hardware and application errors to minimize troubleshooting and reduce MTTR (Mean Time To Repair). Remote diagnostics via the web server function enables service support from anywhere in the world.

Space and energy saving

The CP series E03 controller is only 25% of the standard palletizing controller size (41% with transformer unit) and fits under conveyors and other equipment. The E03 controller generates electric power while in a deceleration mode, reducing energy consumption and minimizing CO2 emissions.



*Option



Teach pendant

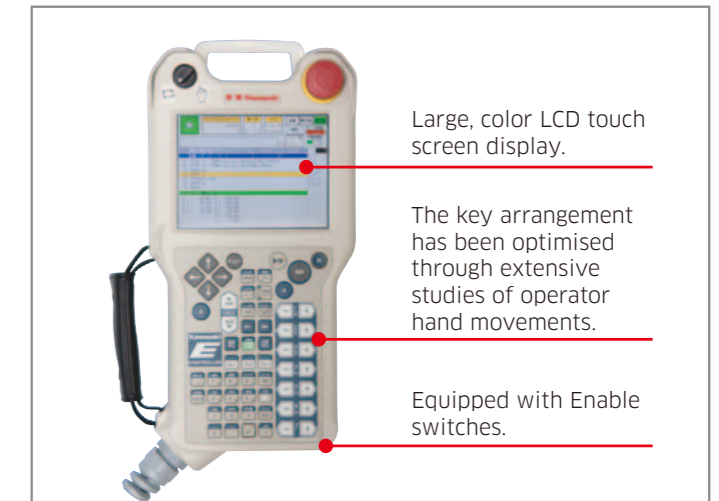

Specifications

		Standard		Standard			Option	
		E03		E23	E43	E33	E03	E33
								E43
								E23
America								
Europe								
Japan & Asia								
Dimensions (mm)		W550×D580×H278		W630×D550×H950	W730×D550×H1,200		Transformer unit: W580×D580×H178	
Structure		Enclosed structure / Indirect cooling system		Enclosed structure / Indirect cooling system				
Number of controlled axes		5		5			6	E33: 8 E43: 8 E23: 7
Drive system		Full digital servo system		Full digital servo system				
Coordinate systems		Joint, Base, Tool		Joint, Base, Tool			Fixed tool point	
Types of motion control		Joint/Linear/Circular Interpolated motion		Joint/Linear/Circular Interpolated motion				
Programming		Point to point teaching or language based programming		Point to point teaching or language based programming				
Memory capacity (MB)		8		8				
General purpose signals	External operation	Motor power off, Hold		Motor power off, Hold				
	Input (Channels)	32		32			Max. 96	Max. 128
	Output (Channels)	32		32			Max. 96	Max. 128
Operation panel		E-Stop switch, teach/repeat switch, control power light		E-Stop switch, teach/repeat switch, control power light	E-Stop switch, teach/repeat/rapid-feed check switch, control power light	E-Stop switch, teach/repeat switch, control power light	Rapid-feed check mode switch	Cycle start switch, motor-on switch, hold/run switch, error light, error reset switch, rapid-feed check mode switch (only on E23)
Cable length	Teach pendant (m)	5		5			10, 15	
	Robot-controller (m)	5		5			10, 15	
Mass (kg)		45		110	195		Transformer unit: 45	
Power requirements		AC200-220V ±10%, 50/60Hz, 3ø		AC200-220V ±10%, 50/60Hz, 3ø	AC380-415V ±10%, 50/60Hz, 3ø	AC440-480V ±10%, 60Hz, 3ø	*Transformer unit AC380-415V ±10% or AC440-480V ±10% 50/60Hz, 3ø	E33 AC200-220V ±10% AC380-415V ±10% AC515V ±10% AC575V ±10% AC440-480V ±10% 50/60Hz, 3ø
		Class-D earth connection (Earth connection dedicated to robots), leakage current: Maximum 100mA		Class-D earth connection (Earth connection dedicated to robots), leakage current: Maximum 100mA				
Environmental condition	Ambient temperature (°C)	0 - 45		0 - 45				
	Relative humidity (%)	35 - 85 (no dew, nor frost allowed)		35 - 85 (no dew, nor frost allowed)				
Body color		Munsell 10GY9/1 equivalent		Munsell 10GY9/1 equivalent				
Teach pendant		TFT color LCD display with touch-panel, E-Stop switch, teach lock switch, Enable switch		TFT color LCD display with touch-panel, E-Stop switch, teach lock switch, Enable switch				
Auxiliary storage unit		-		-			USB Memory	
Interface		USB, Ethernet (100BASE-TX), RS-232C		USB, Ethernet (100BASE-TX), RS-232C				

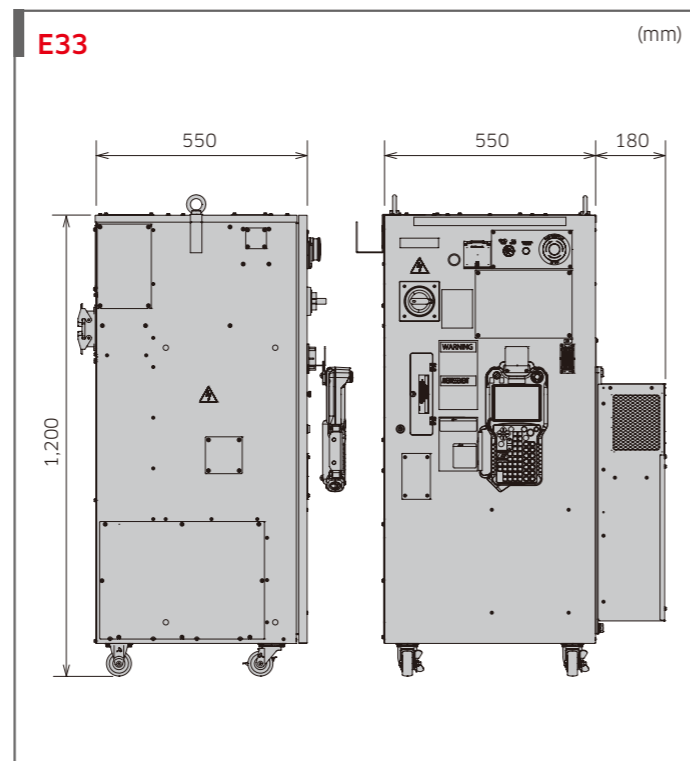
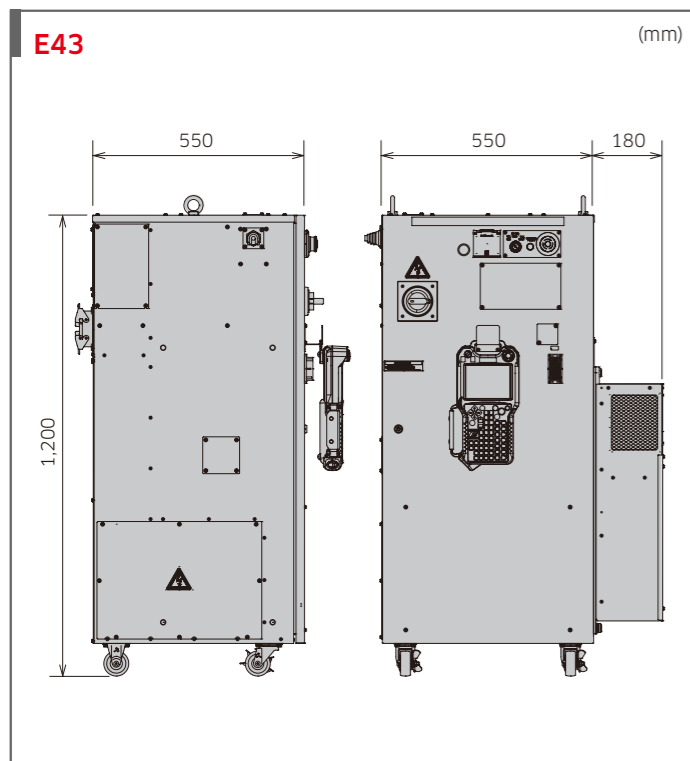
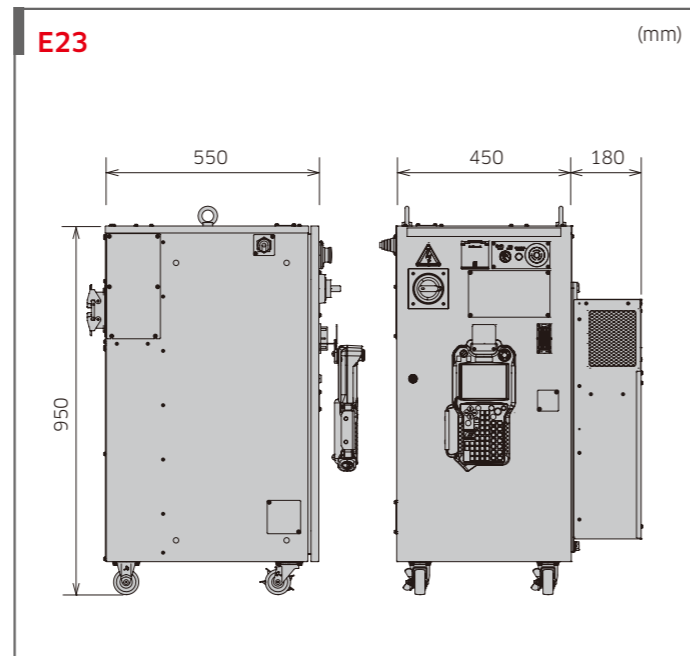
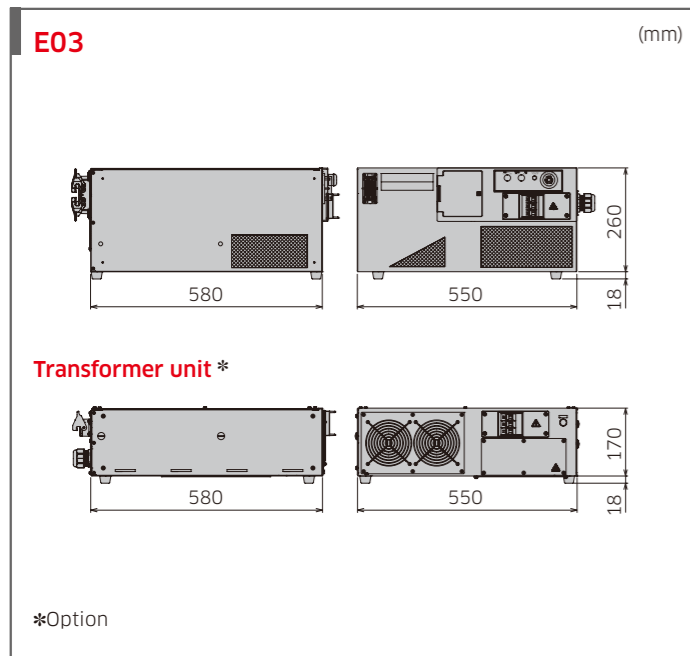

Simple palletizing software (option)

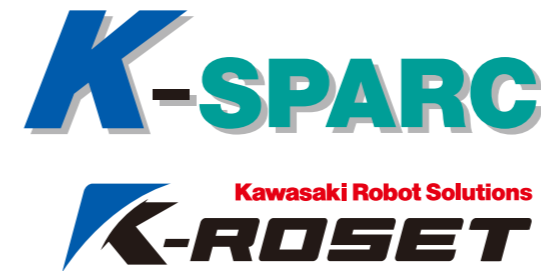

This software lets you configure the pick and place positions of the workpieces by robots and register workpieces, pallets, and stacking patterns displayed on your computer's screen. It also allows you to easily create robot operation programs.

This optional software is one of the application programs built on K-ROSET, Kawasaki's offline teaching software.

Easy setup by layout selection

Support for up to two pick positions and four place positions of workpieces by robots. Simply select a layout and enter a distance!

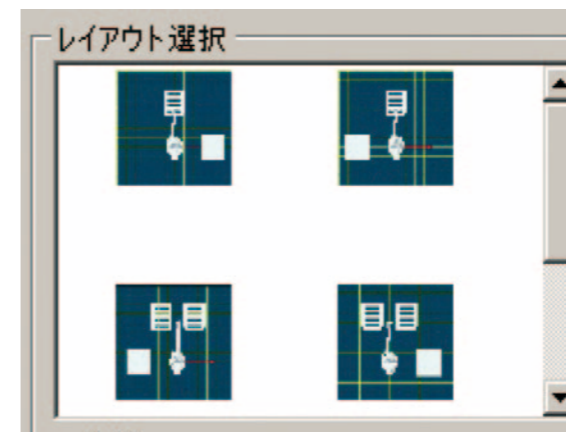

K-ROSET functions can be used

With K-ROSET, users can specify the layout by analyzing the installation positions automatically according to the robot types and place positions. You can also check for interference and perform cycle time analysis.

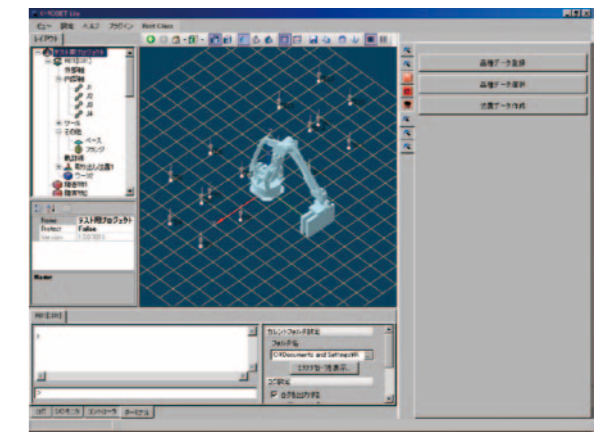

Easy registration of item types

Item types are registered simply by entering data on your computer for workpieces, pallets, and stacking patterns.

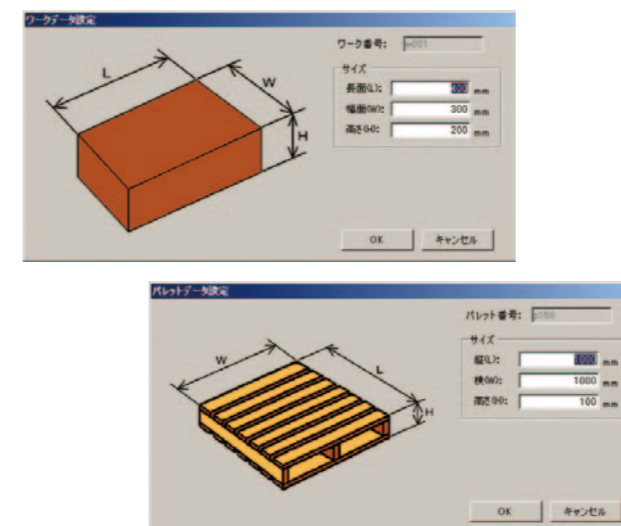

Support for many kinds of stacking patterns

Approximately 100 types of base patterns can be configured for each stage. The place position of workpieces can be specified. Gaps can also be adjusted.

