

# Kawasaki Robot Arc welding robots

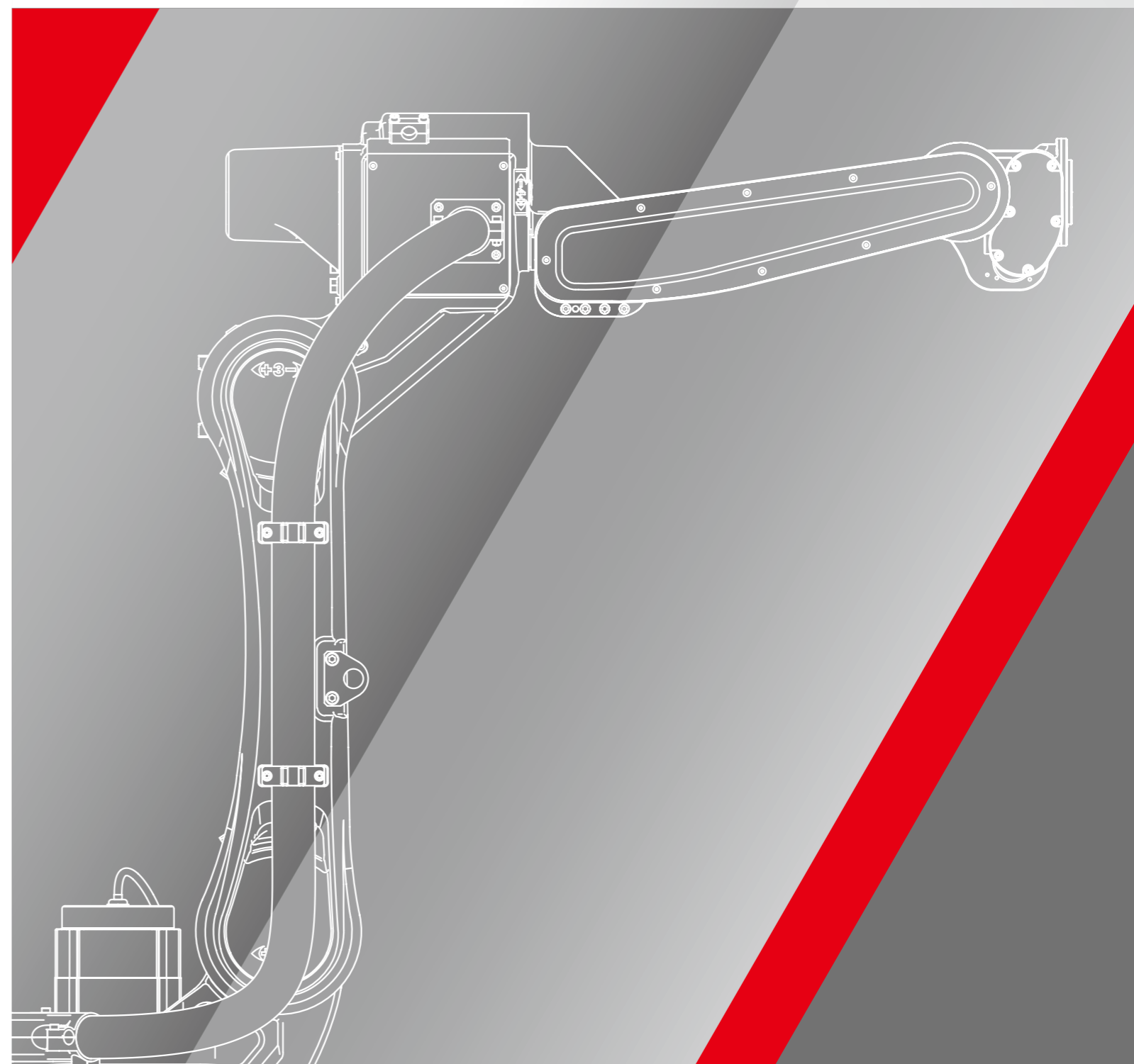

## Kawasaki Heavy Industries, Ltd.

### ROBOT DIVISION

#### Tokyo Head Office/Robot Division

1-14-5, Kaigan, Minato-ku, Tokyo 105-8315, Japan  
Phone: +81-3-3435-6852 Fax: +81-3-3437-9880

#### Akashi Works/Robot Division

1-1, Kawasaki-cho, Akashi, Hyogo 673-8666, Japan  
Phone: +81-78-921-2946 Fax: +81-78-923-6548

### Global Network

#### Kawasaki Robotics (USA), Inc.

28140 Lakeview Drive, Wixom, MI 48393, U.S.A.  
Phone: +1-248-446-4100 Fax: +1-248-446-4200

#### Kawasaki Robotics (UK) Ltd.

Unit 4 Easter Court, Europa Boulevard, Westbrook Warrington  
Cheshire, WA5 7ZB, United Kingdom  
Phone: +44-1925-71-3000 Fax: +44-1925-71-3001

#### Kawasaki Robotics GmbH

29 Sperberweg, 41468 Neuss, Germany  
Phone: +49-2131-34260 Fax: +49-2131-3426-22

#### Kawasaki Robotics Korea, Ltd.

43, Namdong-daero 215beon-gil, Namdong-gu, Incheon, 21633,  
Korea  
Phone: +82-32-821-6941 Fax: +82-32-821-6947

#### Kawasaki Robotics (Tianjin) Co., Ltd.

Bldg 3, No.16, Xiang'an Road, TEDA, Tianjin 300457 China  
Phone: +86-22-5983-1888 Fax: +86-22-5983-1889

#### Kawasaki Motors Enterprise (Thailand) Co., Ltd.

(Rayong Robot Center)  
119/10 Moo 4 T.Pluak Daeng, A.Pluak Daeng, Rayong 21140  
Thailand  
Phone: +66-38-955-040-58 Fax: +66-38-955-145

<https://robotics.kawasaki.com/>

\* Materials and specifications are subject to change without notice.

## Kawasaki Robot

### CAUTIONS TO BE TAKEN TO ENSURE SAFETY

- For those persons involved with the operation / service of your system, including Kawasaki Robot, they must strictly observe all safety regulations at all times. They should carefully read the Manuals and other related safety documents.
- Products described in this catalogue are general industrial robots. Therefore, if a customer wishes to use the Robot for special purposes, which might endanger operators or if the Robot has any problems, please contact us. We will be pleased to help you.
- Be careful as Photographs illustrated in this catalogue are frequently taken after removing safety fences and other safety devices stipulated in the safety regulations from the Robot operation system.



ISO certified in Akashi Works.

# Kawasaki arc welding robots use the latest arc welding technology to rival the quality of a skilled human welder

## Features

### Easy operation

Each robot is equipped standard with an easy to view and operate color LCD touchscreen teach pendant. The operator teaches the process path using dedicated arc welding teaching screens that are designed for simplified use and easy operation.

### Easy connection with the optimum welding equipment

The built-in interface dedicated to arc welding equipment enables an easy connection using a single cable.

### Welding condition database

During an automated process, the operator can change the welding conditions on-the-fly, and then store these changes to a built-in database. The saved conditions can then be recalled from the database and reused.

### Reduced downtime

A standard, dedicated start sequence function improves the arc establishment. Also, for weld process faults, the robot includes a restart sequence function to automatically conduct overlap welding and resume the operation.

### Advanced technology

Servo-torch, touch sensing, special weaving pattern, real-time path modification (RTPM) sensor, start-point sensing, multilayer welding function, and auto voltage control (AVC) sensor are some of the advanced arc welding options available with the Kawasaki welding robots.

### Capable of TIG welding and Plasma welding/cutting

High-noise operations have been carefully considered at the R&D stage. TIG welding and Plasma cutting can be done without difficulties.

### Offline programming

Kawasaki offers arc welding specific offline programming software to automatically generate robot programs from 3D CAD data. Kawasaki's KCONG software significantly reduces robot teaching time and lowers production costs.



		BA006N	BA006L	RA005L	RA006L	RA010N	RA010L	RA020N
Type		Articulated robot						
Degree of freedom (axes)		6						
Max. payload (kg)		6	6	5	6	10	10	20
Max. reach (mm)		1,445	2,036	903	1,650	1,450	1,925	1,725
Positional repeatability (mm) *1		±0.06	±0.08	±0.03	±0.06	±0.06	±0.06	±0.06
Motion range (°)	Arm rotation (JT1)	±165	±165	±180	±180	±180	±180	±180
	Arm out-in (JT2)	+150 - -90	+150 - -90	+135 - -80	+145 - -105	+145 - -105	+155 - -105	+155 - -105
	Arm up-down (JT3)	+90 - -175	+90 - -175	+118 - -172	+150 - -163	+150 - -163	+150 - -163	+150 - -163
	Wrist swivel (JT4)	±180	±180	±360	±270	±270	±270	±270
	Wrist bend (JT5)	±135	±135	±145	±145	±145	±145	±145
	Wrist twist (JT6)	±360	±360	±360	±360	±360	±360	±360
Max. speed (°/s)	Arm rotation (JT1)	240	210	300	250	250	190	190
	Arm out-in (JT2)	240	210	300	250	250	205	205
	Arm up-down (JT3)	220	220	300	215	215	210	210
	Wrist swivel (JT4)	430	430	460	365	365	400	400
	Wrist bend (JT5)	430	430	460	380	380	360	360
	Wrist twist (JT6)	650	650	740	700	700	610	610
Moment (N·m)	Wrist swivel (JT4)	12	12	12.3	13	22	22	45
	Wrist bend (JT5)	12	12	12.3	13	22	22	45
	Wrist twist (JT6)	3.75	3.75	7	7.5	10	10	29
Moment of Inertia (kg·m <sup>2</sup> )	Wrist swivel (JT4)	0.4	0.4	0.4	0.45	0.7	0.7	0.9
	Wrist bend (JT5)	0.4	0.4	0.4	0.45	0.7	0.7	0.9
	Wrist twist (JT6)	0.07	0.07	0.12	0.14	0.2	0.2	0.3
Mass (kg)		150	160	37	150	150	230	230
Body color		Munsell 10GY9/1 equivalent						
Installation		Floor, Ceiling						
Environmental condition	Ambient temperature (°C)	0 - 45						
	Relative humidity (%)	35 - 85 (No dew, nor frost allowed)						
Power requirements (kVA) *2		2.0	2.0	1.5	2.0	2.0	3.0	3.0
Controller	America	E01		E77	E01			
	Europe			E71				
	Japan & Asia			E74				

\*1: conforms to ISO9283 \*2: depends on the payload and motion patterns

### Optional equipment

- Shock sensor
- Torch bracket (350 A/500 A)
- Installation base (600 mm / 300 mm)
- Base plate (750 mm × 750 mm × 25 mm)
- Linear slide
- Positioner
- Servo torch
- RTPM (arc sensor)
- AVC (arc-sensor dedicated to TIG welding)
- 3D laser sensor
- Wall mounting

### KCONG Kawasaki Common Offline NC data Generator

KCONG, our offline programming software, automatically generates a robot's welding path based off of workpiece geometry.

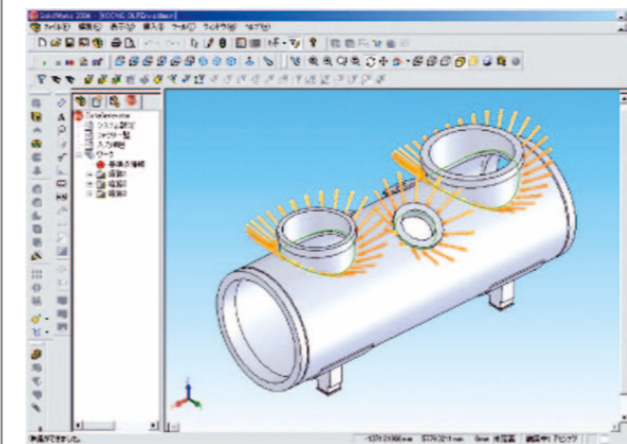

#### Features

##### No need for time-consuming robot teaching

KCONG generates robot welding paths quickly and easily from 3D CAD data such as DXF, IGES, STEP or VRML.

##### Offline process verification

Once KCONG automatically generates the robot welding path, users can then view the simulation of the arc welding process, check for collisions, weld access, and system layout issues, and make fine adjustments to the generated welding path.

##### Direct program download

After verifying the weld process and making any necessary adjustments, the operation program is generated by KCONG. The completed weld operation program can then be downloaded directly to the robot controller.

### Servo Torch

Kawasaki's servo torch option delivers high quality welding.

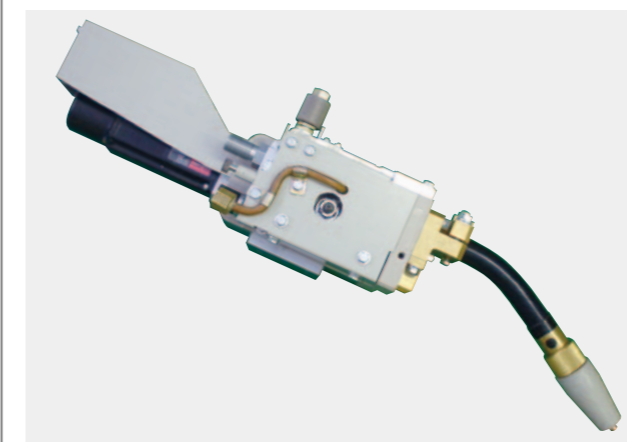

#### Features

##### Can be used with small-gauge iron or aluminum wire

Feeds small-gauge iron wire (ø 0.6 mm) or aluminum wire steadily with no buckling.

##### Excellent arc stability

The constant-speed wire feed control improves wire feeding performance, resulting in excellent arc stability.

##### Improved arc ignition performance

The servo torch can control complex wire feeding at the start and end of welding operations, thereby improving arc ignition.

**BA006N**

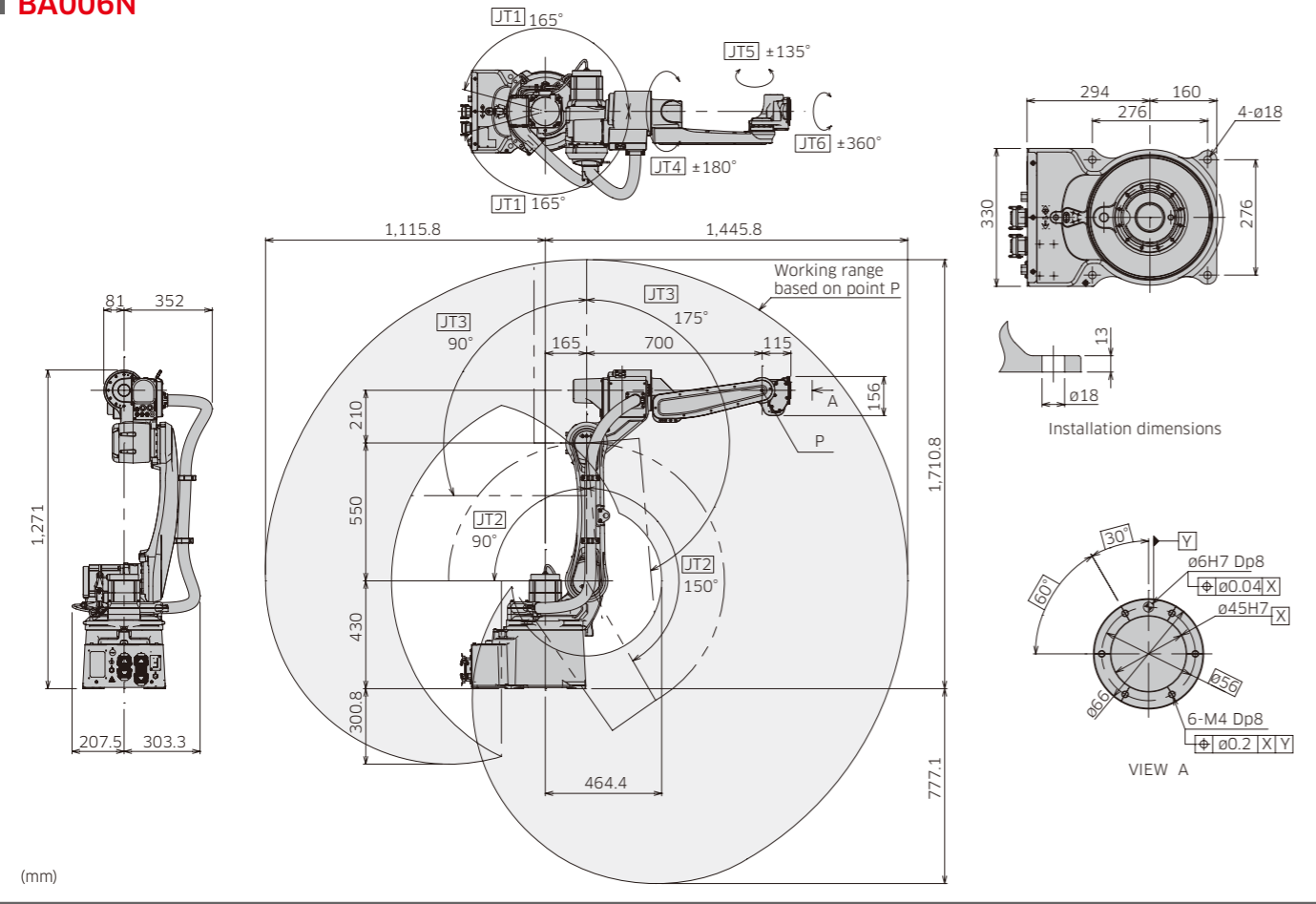

(mm)

**RA005L**

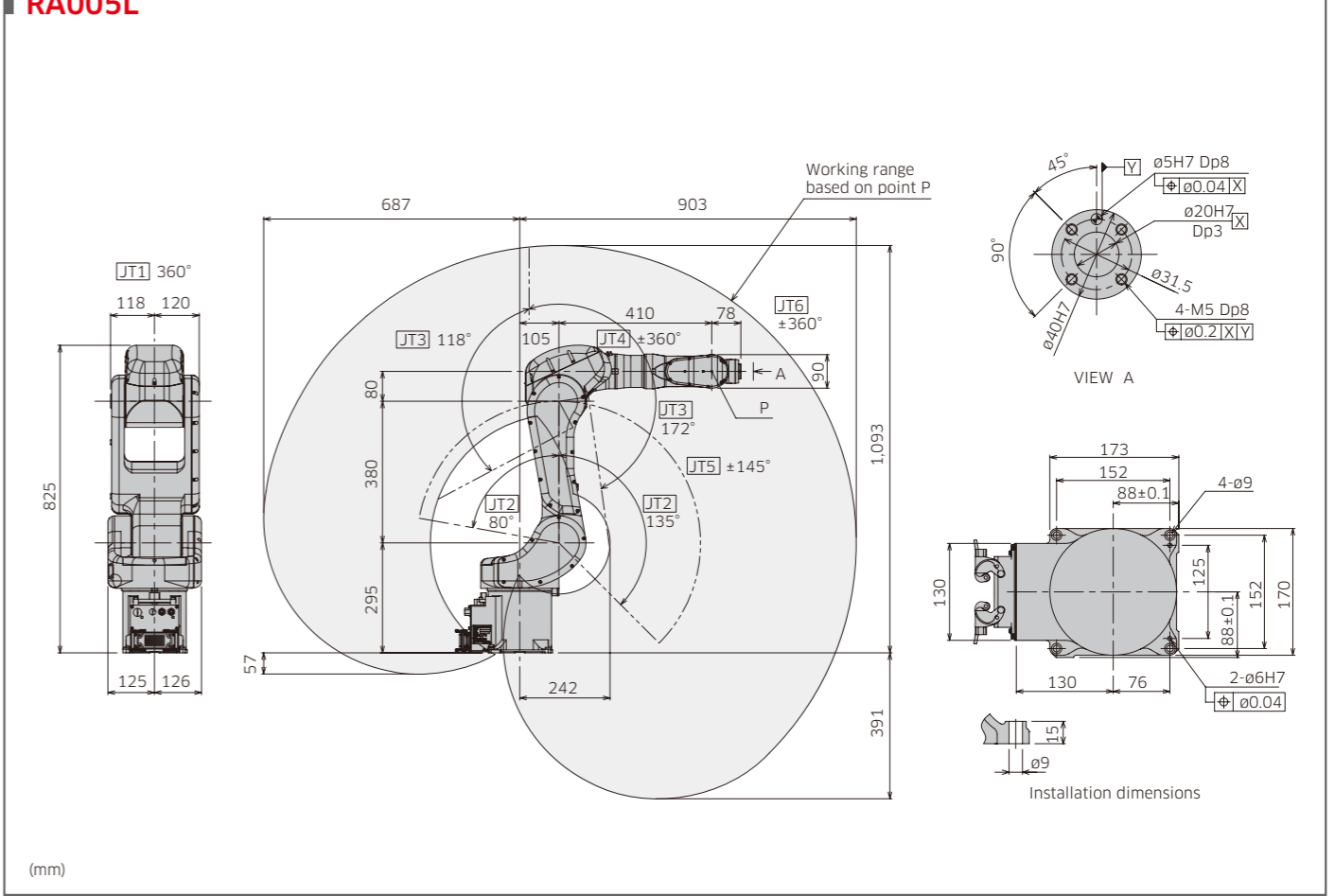

(mm)

**BA006L**

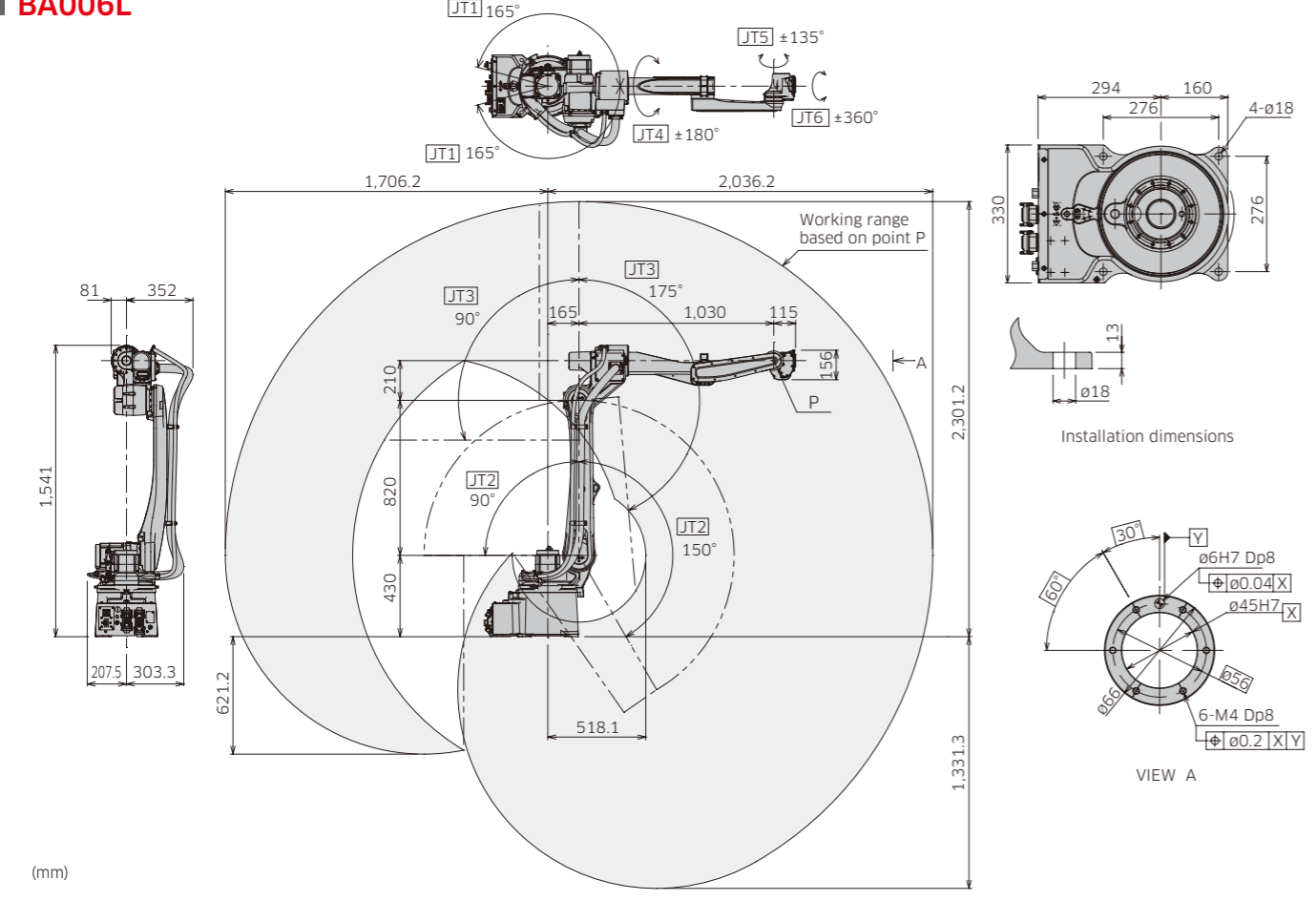

(mm)

**RA006L**

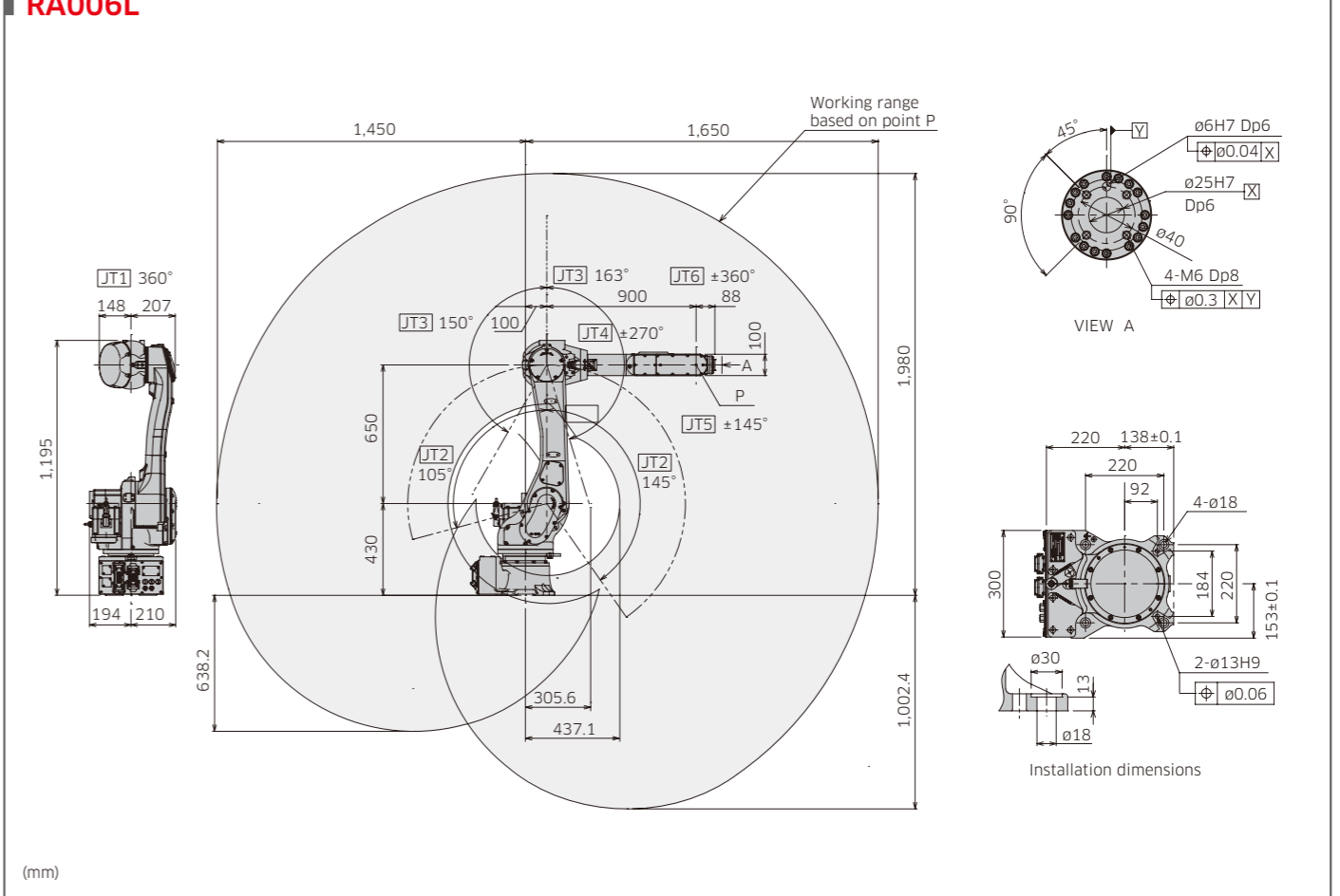

(mm)

**RA010N**

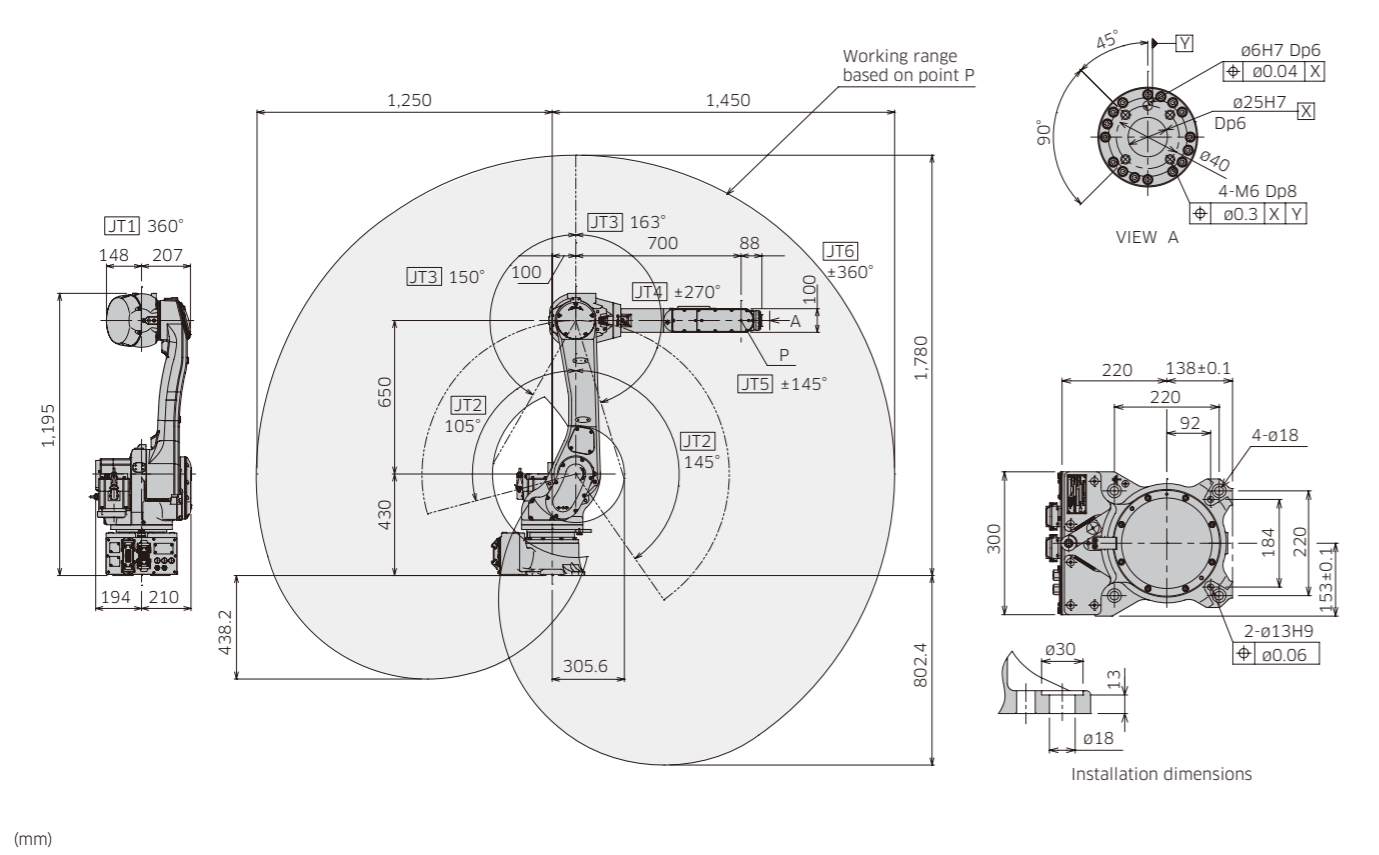

**RA020N**

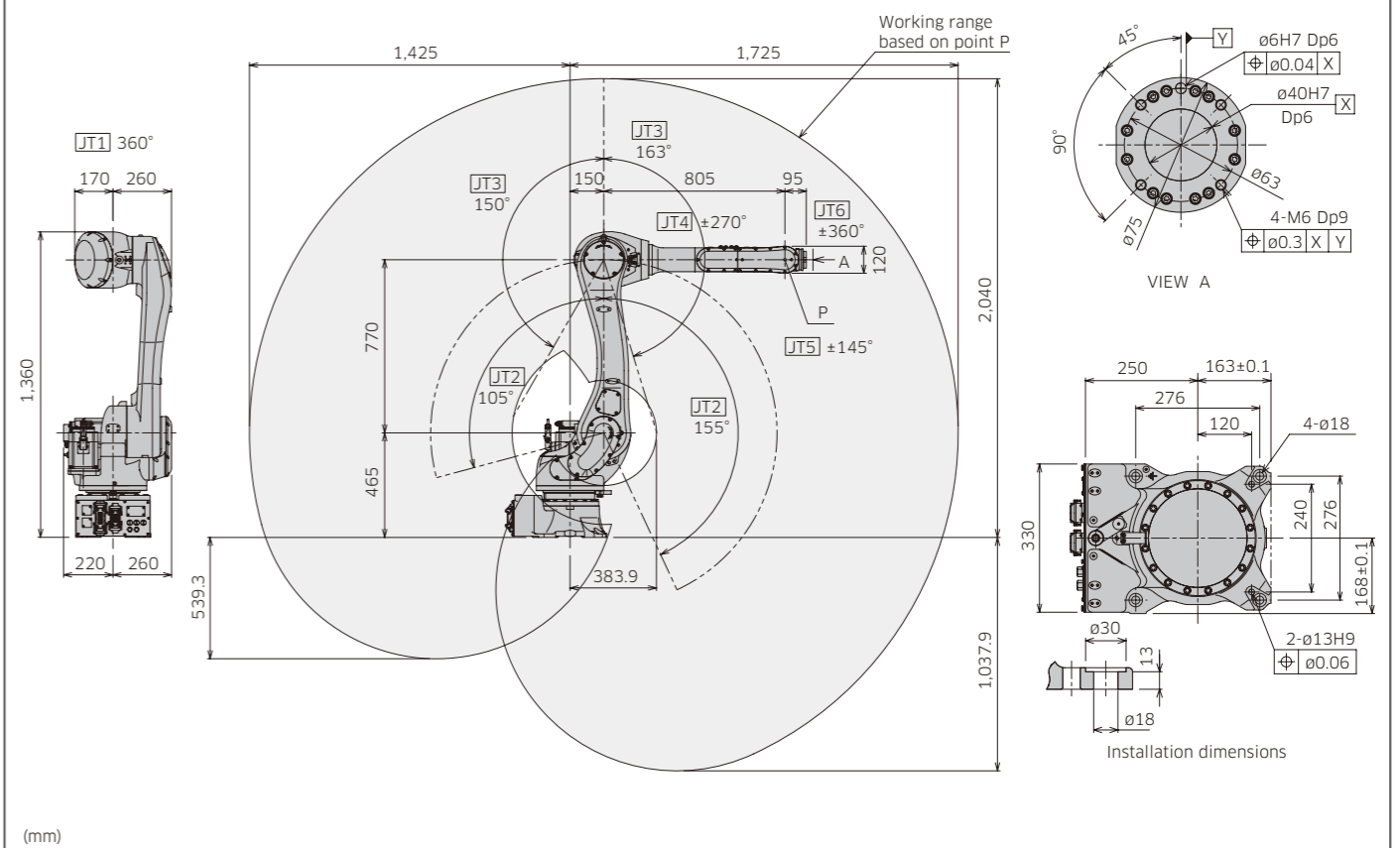

**RA010L**

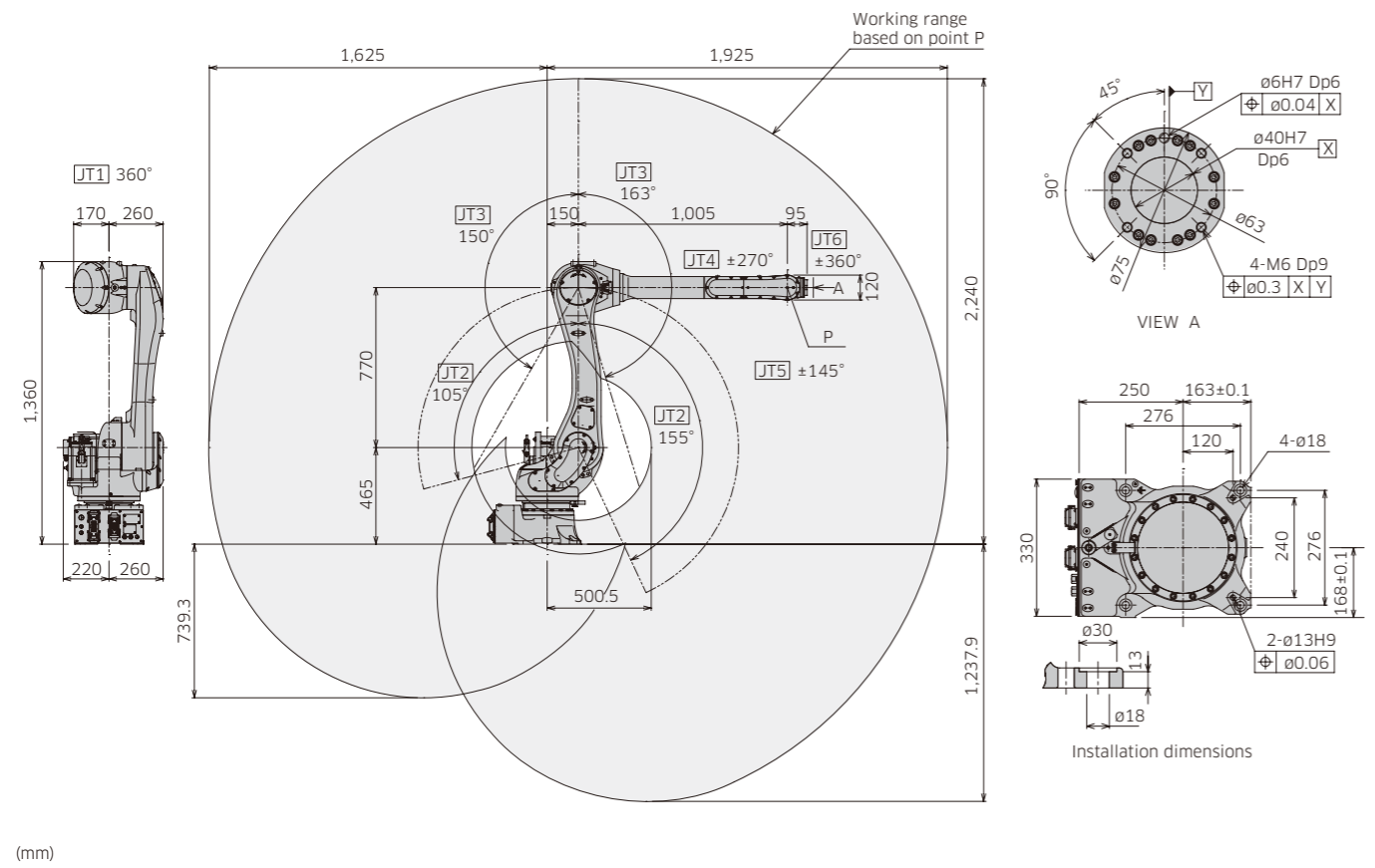

# E series

## - An evolution of engineering excellence

Kawasaki has incorporated more than 45 years of experience as a robot industry leader into the development of the most technically advanced controller available. The E Controller combines high performance, unprecedented reliability, a host of integrated features and simple operation, all in a compact design.



### Features

#### Compact

The overall volume of the E Controller has been reduced compared with the previous model. The small footprint of this compact controller allows for installation in "high-density" applications. For further space saving options, an upright-position or stacked installation\* is possible, without impeding performance.

\*E01 only

#### User-friendly operation

The easy-to-use teach pendant now incorporates motor power and cycle start at your fingertips. Multiple information screens can be displayed simultaneously. The intuitive teaching interface is simple to use.

#### Programming ease & flexibility

A rich set of programming functions come standard with the E Controller to support a wide range of applications. Functions can be combined and easily configured within a system to suit a particular application. Also, the powerful Kawasaki AS Programming Language provides sophisticated robot motion and sequence controls.

#### Advanced technologies

The enhanced CPU capacity allows for more accurate trajectory control, faster program execution, and quicker loading and saving of files. In addition, memory has been expanded to meet the need for higher program storage capacity. The controller comes equipped with a USB port for external storage devices.

#### Easy maintenance

Modular components with limited cables translate into easy diagnostics and maintenance. A host of maintenance functions are available, including self-diagnostics on hardware and application errors to minimize troubleshooting and reduce MTR (Mean Time To Repair). Remote diagnostics via the web server function enables service support from anywhere in the world.

#### Expandable

Three external axes can be added to the E01 controller for a total of nine controlled axes, while two can be added to the E7X for a total of eight controlled axes. Numerous communication fieldbuses are available for controlling peripheral devices. The Kawasaki K-Logic sequencer software can be combined with user customized interface panels on the teach pendant.

### External view & dimensions

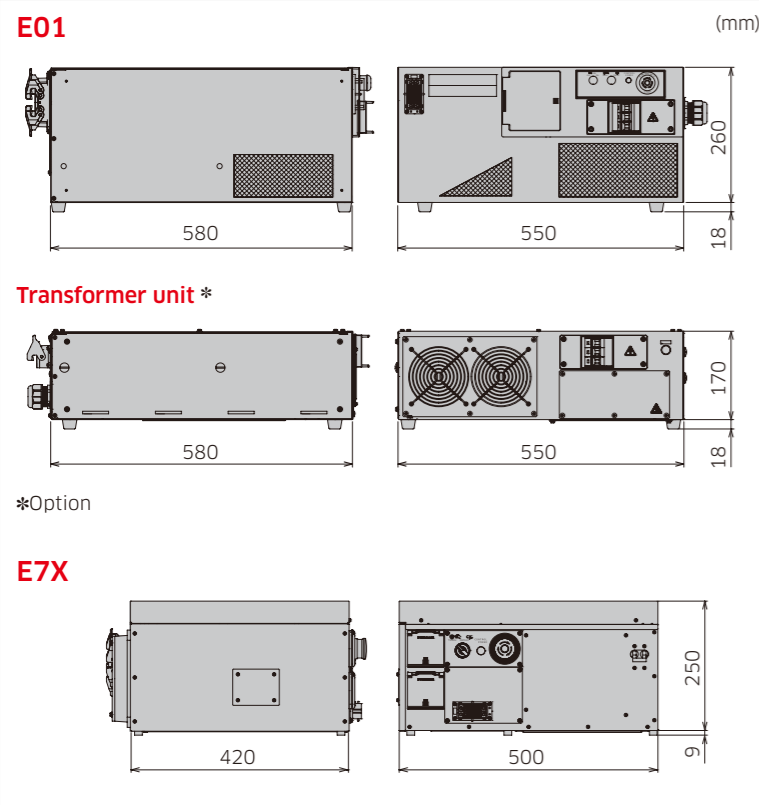

### Specifications

		Standard		Option
		E01	E77 E71 E74	
America		E01	E77	Option
Europe			E71	
Japan & Asia			E74	
Dimensions (mm)		W550×D580×H278	W500×D420×H259	Transformer unit: W580×D580×H178 (E01 only)
Structure		Enclosed structure / Indirect cooling system		
Number of controlled axes		7	6	Max. 9 (E01) Max. 8 (E7X)
Drive system		Full digital servo system		
Coordinate systems		Joint, Base, Tool		Fixed tool point
Types of motion control		Joint/Linear/Circular Interpolated motion		
Programming		Point to point teaching or language based programming		
Memory capacity (MB)		8		
General purpose signals	External operation	Motor power off, Hold		
	Input (Channels)	32		
	Output (Channels)	32		
Operation panel		E-Stop switch, teach/repeat switch, control power light (Cycle start, motor-on, hold/run, and error reset are activated from the teach pendant.)		Cycle start switch, motor-on switch, hold/run switch, error light, error reset switch (E7X), rapid-feed check mode switch
Cable length	Teach pendant (m)	5		10, 15
	Robot-controller (m)	5		10, 15
Mass (kg)		40	30	Transformer unit: 45 (E01 only)
Power requirements		AC200-220V ±10%, 50/60Hz, 3ø	AC200-240V ±10% 50/60Hz 1ø	*Transformer unit (E01 only) AC380-415V ±10% or AC440-480V ±10% 50/60Hz, 3ø
		Class-D earth connection (Earth connection dedicated to robots), leakage current: Maximum 100mA		
Environmental condition	Ambient temperature (°C)	0 - 45 (0 - 40 for E7x in vertical use)		
	Relative humidity (%)	35 - 85 (no dew, nor frost allowed)		
Body color		Munsell 10GY9/1 equivalent	-	-
Teach pendant		TFT color LCD display with touch-panel, E-Stop switch, teach lock switch, Enable switch		
Auxiliary storage unit		-		
Interface		USB, Ethernet (100BASE-TX), RS-232C		

### System configuration diagram

